

CDMA2000[®] incl. 1xEV-DV Digital Standard for R&S[®] Signal Generators Operating Manual



1171.5225.12 – 19

This document describes the following software options:

- R&S®SMBV-K46
1415.8083.xx
- R&S®SMU-K46
1160.9876.02
- R&S®AMU-K46
1402.6506.02
- R&S®SMATE-K46
1404.5507.02
- R&S®SMJ-K46
1409.1016.02

This manual version corresponds to firmware version:

FW 3.50.082.xx and later of the R&S®SMBV100A

FW 3.20.286.xx and later of the R&S®SMU200A, R&S®SMATE200A, R&S®SMJ100A and R&S®AMU200A

© 2016 Rohde & Schwarz GmbH & Co. KG

Mühlhofstr. 15, 81671 München, Germany

Phone: +49 89 41 29 - 0

Fax: +49 89 41 29 12 164

Email: info@rohde-schwarz.com

Internet: www.rohde-schwarz.com

Subject to change – Data without tolerance limits is not binding.

R&S® is a registered trademark of Rohde & Schwarz GmbH & Co. KG.

CDMA2000® is a registered trademark of the Telecommunications Industry Association (TIA -USA).

Trade names are trademarks of the owners.

The following abbreviations are used throughout this manual: R&S®SMBV100A is abbreviated as R&S SMBV, R&S®SMU200A is abbreviated as R&S SMU, R&S®AMU200A is abbreviated as R&S AMU, R&S®SMATE200A is abbreviated as R&S SMATE, R&S®SMJ100A is abbreviated as R&S SMJ, R&S®WinIQSIM2™ is abbreviated as R&S WinIQSIM2; the license types 02/03/07/11/13/16/12 are abbreviated as xx.

Contents

1	Preface	7
1.1	Documentation Overview.....	7
1.2	Typographical Conventions.....	8
1.3	Notes on Screenshots.....	9
2	Introduction	10
3	Modulation System CDMA2000	12
3.1	Modulation System CDMA2000 in the Downlink (Forward).....	12
3.2	Modulation System CDMA2000 in the Uplink (Reverse).....	12
3.3	Data Source - Uplink and Downlink.....	13
3.4	Channel Coding - Uplink and Downlink.....	13
3.5	Long-Code Scrambling Generator - Downlink.....	14
3.6	Power Control Puncturing - Downlink.....	15
3.7	Variable-Length Walsh Spreading - Downlink.....	15
3.8	PN Short-Code Scrambling - Downlink.....	15
3.9	Spreading - Uplink.....	15
3.9.1	Variable Length Walsh Spreading.....	16
3.9.2	64-Ary Orthogonal Modulator.....	16
3.10	Scrambling - Uplink.....	16
3.10.1	Scrambling for Radio Configuration 1 and 2	16
3.10.2	Scrambling for Radio Configuration 3, 4 and 5.....	18
3.11	Baseband Filtering - Uplink and Downlink.....	19
3.12	I/Q Modulator - Uplink and Downlink.....	19
3.13	Constellation of I/Q Signals - Downlink.....	20
3.13.1	BPSK channels.....	20
3.13.2	QPSK channels.....	20
3.14	Power Control - Downlink and Uplink.....	21
4	User Interface	22
4.1	General Settings for CDMA2000 Signals.....	23
4.2	Configure Base Station or Mobile Station.....	27
4.3	Filter / Clipping / ARB Settings.....	31

4.3.1	Filter Settings.....	31
4.3.2	Clipping Settings.....	32
4.3.3	ARB Settings.....	34
4.3.4	I/Q Setting.....	34
4.4	Trigger/Marker/Clock Settings.....	35
4.4.1	Trigger In.....	36
4.4.2	Marker Mode.....	40
4.4.3	Marker Delay.....	41
4.4.4	Clock Settings.....	42
4.4.5	Global Settings.....	43
4.5	Predefined Settings - Downlink.....	44
4.6	Additional Mobile Station - Uplink.....	47
4.7	Base Station Configuration.....	48
4.7.1	Common Settings.....	49
4.7.2	Code Domain and Channel Graphs.....	51
4.7.3	Channel Table - BS.....	55
4.8	More Parameters - BS Channel Table.....	61
4.8.1	General Settings.....	63
4.8.2	Power Control.....	64
4.8.3	Channel Coding.....	66
4.8.4	Additional Sync Channel Parameters.....	68
4.8.5	Error Insertion.....	70
4.9	More Parameters for F-PDCH - BS.....	71
4.9.1	General Settings for Packet Channel.....	72
4.9.2	Subpacket Table Settings.....	73
4.9.3	Subpacket Graph.....	76
4.10	Mobile Station Configuration (MS).....	76
4.10.1	Common Settings - MS.....	77
4.10.2	Power Control - MS.....	78
4.10.3	Channel Table - MS.....	80
5	Remote-Control Commands.....	85
5.1	Primary Commands.....	86
5.2	Filter/Clipping Settings.....	93

5.2.1	Filter Settings.....	93
5.2.2	Clipping Settings.....	96
5.3	Trigger Settings.....	98
5.4	Marker Settings.....	102
5.5	Clock Settings.....	105
5.6	Predefined Settings.....	107
5.7	Base Stations Settings.....	112
5.8	Mobile Station Settings.....	144
	List of Commands.....	157
	Index.....	161

1 Preface

1.1 Documentation Overview

This section provides an overview of the R&S Signal Generator user documentation. You find it on the product page at:

<http://www.rohde-schwarz.com/product/SMBV100A.html> > "Downloads"

Quick start guide

Introduces the R&S Signal Generator and describes how to set up and start working with the product. Includes basic operations, typical measurement examples, and general information, e.g. safety instructions, etc. A printed version is delivered with the instrument.

Online help

Offers quick, context-sensitive access to the complete information for the base unit and the software options directly on the instrument.

Operating manual

Separate manuals for the base unit and the software options are provided for download:

- Base unit manual
Contains the description of all instrument modes and functions. It also provides an introduction to remote control, a complete description of the remote control commands with programming examples, and information on maintenance, instrument interfaces and error messages. Includes the contents of the quick start guide manual.
- Software option manual
Contains the description of the specific functions of an option. Basic information on operating the R&S Signal Generator is not included.

The **online version** of the operating manual provides the complete contents for immediate display on the Internet.

Service manual

Describes the performance test for checking the rated specifications, module replacement and repair, firmware update, troubleshooting and fault elimination, and contains mechanical drawings and spare part lists.

The service manual is available for registered users on the global Rohde & Schwarz information system (GLORIS, <https://gloris.rohde-schwarz.com>).

Instrument security procedures manual

Deals with security issues when working with the R&S Signal Generator in secure areas.

Basic safety instructions

Contains safety instructions, operating conditions and further important information. The printed document is delivered with the instrument.

Data sheet and brochure

The data sheet contains the technical specifications of the software options, see "Digital Standards for Signal Generators - Data sheet" on the web site. It also lists the options and their order numbers.

The brochure provides an overview of the instrument and deals with the specific characteristics.

Release notes and open source acknowledgment (OSA)

The release notes of the base units list new features, improvements and known issues of the current firmware version, and describe the firmware installation.

The open source acknowledgment document provides verbatim license texts of the used open source software. See the product page of the base unit, e.g. at:

<http://www.rohde-schwarz.com/product/SMBV100A.html> > "Downloads" > "Firmware"

Application Notes, Application Cards, White Papers, etc.

These documents deal with special applications or background information on particular topics, see <http://www.rohde-schwarz.com/appnotes>.

1.2 Typographical Conventions

The following text markers are used throughout this documentation:

Convention	Description
"Graphical user interface elements"	All names of graphical user interface elements on the screen, such as dialog boxes, menus, options, buttons, and softkeys are enclosed by quotation marks.
KEYS	Key names are written in capital letters.
File names, commands, program code	File names, commands, coding samples and screen output are distinguished by their font.
<i>Input</i>	Input to be entered by the user is displayed in italics.

Convention	Description
Links	Links that you can click are displayed in blue font.
"References"	References to other parts of the documentation are enclosed by quotation marks.

1.3 Notes on Screenshots

When describing the functions of the product, we use sample screenshots. These screenshots are meant to illustrate as much as possible of the provided functions and possible interdependencies between parameters. The shown values may not represent realistic test situations.

The screenshots usually show a fully equipped product, that is: with all options installed. Thus, some functions shown in the screenshots may not be available in your particular product configuration.

2 Introduction

The R&S SMx/AMU-K46 is a firmware application that adds functionality to generate signals in accordance with the standard CDMA2000.



To play back a signal from a waveform file created by the simulation software R&S WinIQSIM2, the corresponding R&S WinIQSIM2 digital standard option must be installed.

CDMA2000 is the North American standard for the third mobile radio generation (3G). It is a further development of the North American mobile radio system of the second-generation IS95 (CDMA). The R&S Signal Generator supports the CDMA2000 standard 3GPP2 C.S0002-C, version 1.0, May 2002 (release C). CDMA2000® is a registered trademark of the Telecommunications Industry Association (TIA –USA).

The R&S Signal Generator generates the CDMA2000 signals with a chip rate of 1,2288 Mcps, corresponding to the so-called "Spreading Rate 1".

The CDMA2000 signals of the base station are generated in a combination of realtime mode (realtime channels) and arbitrary waveform mode. Simulation of bit and block errors can be activated for the channels generated in real time. In arbitrary waveform mode, the signal is first calculated and then output.

The CDMA2000 signals of mobile station 1 (MS1) are always generated in realtime mode, the signals of the three remaining mobile stations always in arbitrary waveform mode.

In R&S SMBV, the CDMA2000 signal is generated in arbitrary waveform mode, i.e. the signal is first calculated and then output.

The R&S Signal Generator simulates CDMA2000 at the physical channel level. The following list gives an overview of the provided options for generating a CDMA2000 signal:

- Configuration of up to four base stations or four mobile stations
- Realtime generation of one traffic channel and the SYNC channel on the downlink
- All special channels and up to 78 channels on the downlink (depending on the radio configuration)
- Packet channel according to 1xEV-DV on the downlink
- Operating modes "Traffic", "Access", "Enhanced Access" and "Common Control" on the uplink
- "Misuse For Output Power Control" parameter for varying the original normal transmit power over time
- Simulation of up to 64 additional mobile stations
- Clipping for reducing the crest factor
- All channel coding modes included in IS-2000 (Frame Quality Indicator, Convolutional Encoder, Turbo Encoder, Symbol Puncture, Interleaver, etc.)
- Feeding through of bit errors (to test a BER tester) and block errors (to test a BLER tester)

R&S SMBV does not support realtime channels and bit and block errors insertion.

Parameter	Value
Spreading rate	1.2288 MHz
Channel types	Downlink: <ul style="list-style-type: none"> • Forward Pilot (F-PICH) • Sync (F-SYNC) • Paging (F-PCH) • Transmit Diversity Pilot (F-TDPICH) • Auxiliary Pilot (F-APICH) • Auxiliary Transmit Diversity Pilot (F-ATDPCH) • Broadcast (F-BCH) • Quick Paging (F-QPCH) • Common Power Control (F-CPCCH) • Common Assignment (F-CACH) • Forward Common Control (F-CCCH) • Packet Channels • Forward Packet Data Control (F-PDCCH) • Forward Packet Data (F-PDCH) • Traffic Channels • Forward Dedicated Control (F-DCCH) • Forward Fundamental (F-FCH) • Forward Supplemental (F-SCH) Uplink: <ul style="list-style-type: none"> • Reverse Pilot (R-PICH) • Access (R-ACH) • Enhanced Access (R-EACH) • Reverse Common Control (R-CCCH) • Traffic Channel • Reverse Dedicated Control (R-DCCH) • Reverse Fundamental (R-FCH) • Reverse Supplemental Code (R-SCCH) • Reverse Supplemental (R-SCH)
Channel count	In downlink 4 base stations each with up to 78 code channels (depending on the radio configuration). In uplink 4 mobile stations with up to 8 code channels (depending on the radio configuration).
Radio configuration	RC 1 to RC 5 & RC10
Frame length	Radio frame: 5 ms, 10 ms, 20 ms, 40 ms, 80 ms, 160 ms (depending on the channel type and the radio configuration)
PN offset	0 to 511
Quasi Orthogonal Walsh Set	Set 1 to set 3
Channel coding	All channel coding modes included in IS-2000 (Frame Quality Indicator, Convolutional Encoder, Turbo Encoder, Symbol Puncture, Interleaver, etc.)
Long Code Mask	0 to 3FF FFFF FFFF hex

3 Modulation System CDMA2000

The following simplified diagram is used to explain the system principle of CDMA2000 in the forward (down) and reverse (up) link. The exact system configuration depends on parameters like link direction, spreading rate, mode, radio configuration and channel type. A detailed description cannot be given in this manual. For further information, refer to the IS2000 standard.

3.1 Modulation System CDMA2000 in the Downlink (Forward)

The following block diagram shows the components of the CDMA2000 transmission system in the downlink.

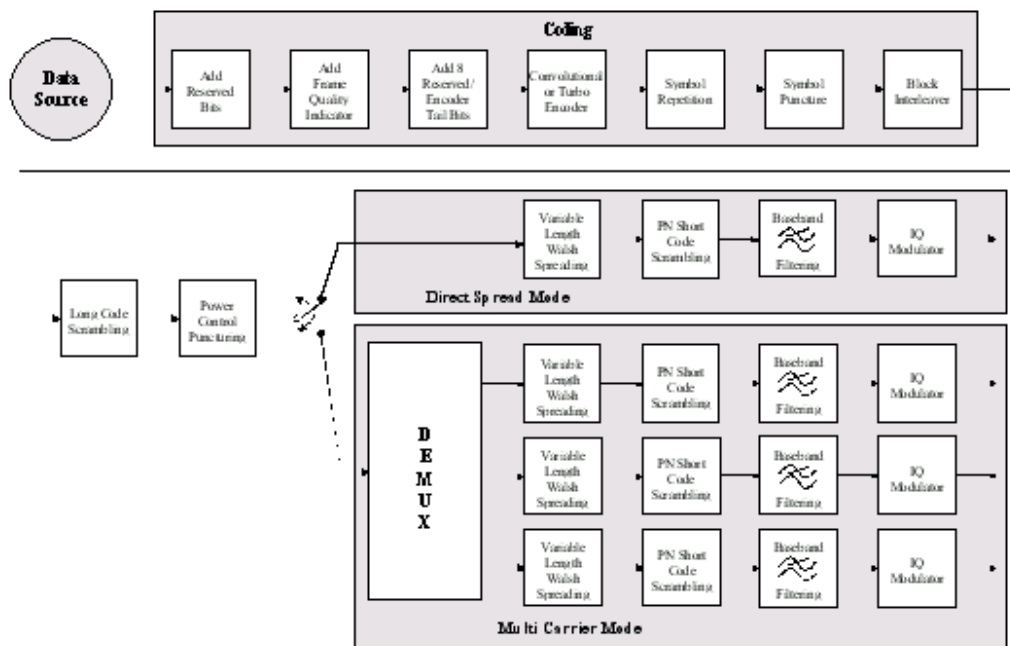

Figure 3-1: Components of the CDMA2000 transmission system in the downlink (forward)

3.2 Modulation System CDMA2000 in the Uplink (Reverse)

The following block diagram shows the components of the CDMA2000 transmission system in the uplink.

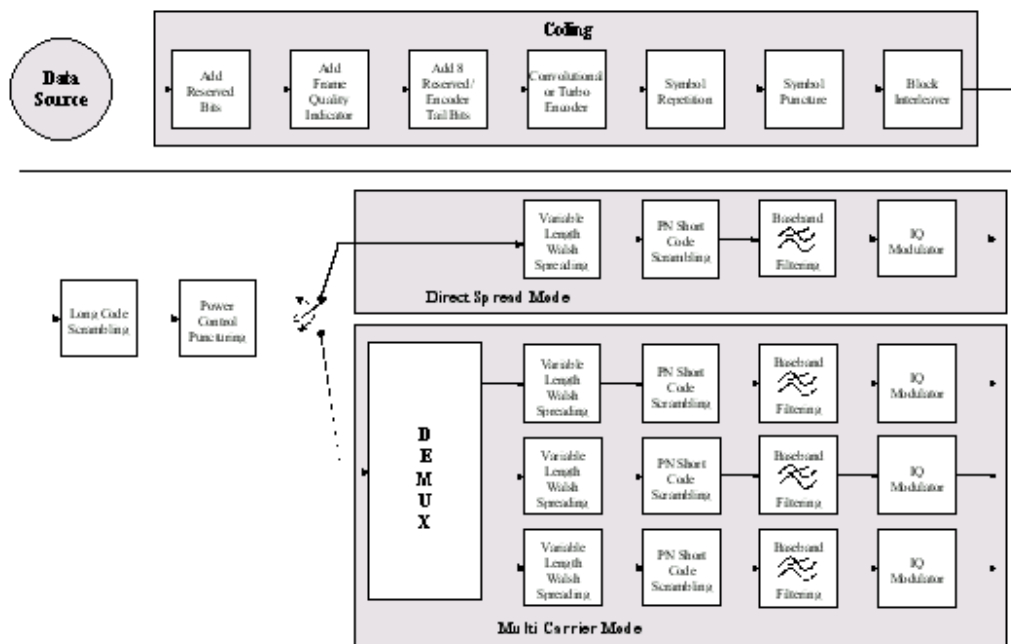

Figure 3-2: Components of the CDMA2000 transmission system in the uplink (reverse)

3.3 Data Source - Uplink and Downlink

The data fields of all channels can be filled from all possible data sources: pattern (all1, all0, user-defined up to 64 bits), PRBS data, data lists and external data.

3.4 Channel Coding - Uplink and Downlink

In contrast to 3GPP FDD, channel coding with CDMA2000 is part of the physical layer. The channel coding procedure can slightly vary depending on channel type, frame length and data rate. The basic coding procedure is illustrated by the coding block in the diagram above.

For a more exact definition, refer to the standard.

- Add reserved bits:** filled with "0" bits
- Add frame quality indicator:** calculation and insertion of a CRC (cyclic redundancy code) checksum for error identification.
- Add 8 reserved/encoder**
- Tail bits:** reserved, tail bits which set the subsequent coder to a defined final state.
- Convolutional or turbo encoder:** error correction code, depending on data rate and other parameters either by convolutional coding or turbo codes.

- Symbol repetition:** symbol repetition is used together with block symbol puncture for adapting the convolutional or turbo coder output data rate to the required input data rate of the interleaver.
- Symbol puncture:** symbol puncturing (elimination) is used together with block symbol repetition for adapting the convolutional or turbo coder output data rate to the required input data rate of the interleaver.
- Block interleaver:** block-wise permutation of input data sequence of interleaver to reduce bit errors.

3.5 Long-Code Scrambling Generator - Downlink

The long-code generator is also referred to as scrambling code generator since it scrambles the chip sequence in a user-specific way (long-code mask).

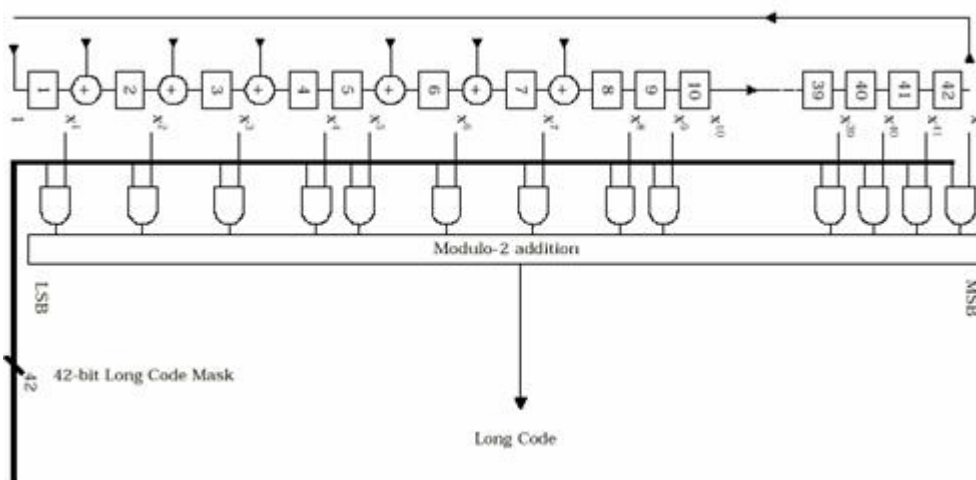

Figure 3-3: Long-code generator CDMA2000

The long-code generator is a feedback 42-bit shift register with its status vector linked to a user-specific long-code mask to form the specific long-code sequence.

The generator polynomial of the shift-register section of the long-code generator is:

$$p(x) = x^{42} + x^{35} + x^{33} + x^{31} + x^{27} + x^{26} + x^{25} + x^{22} + x^{21} + x^{19} + x^{18} + x^{17} + x^{16} + x^{10} + x^7 + x^6 + x^5 + x^3 + x^2 + x + 1$$

A real long code is used in the forward link. In the reverse link, a complex long code with I and Q component is required. The long code for the I component is derived directly from the 1X generator, that for the Q component corresponds to the I long code delayed by one chip.

3.6 Power Control Puncturing - Downlink

To control the output power of the mobile station, the BS sends power control bits in the traffic channel at an 800 Hz rate instead of the scrambled data bits. Depending on the power control bits, the mobile station increases or reduces its output power.

3.7 Variable-Length Walsh Spreading - Downlink

Spreading of the CDMA2000 signal is performed in this block. Walsh codes with a variable spreading factor are used. The spreading factor and the Walsh code depend on the spreading rate, channel type, frame length and data rate. To extend the base-station capacity, so-called 'quasi-orthogonal Walsh sets' can be used in addition to the Walsh codes. The input data stream of the spreading unit is already complex ($I + jQ$). If a standard Walsh code is used, spreading is performed by multiplying the input symbol (modulo 2 multiplication) with the real Walsh code. The quasi-orthogonal Walsh code results in complex spreading through an additional rotation of the output phase (the spreading code then consists of a real and an imaginary part).

3.8 PN Short-Code Scrambling - Downlink

The (complex) input data stream of the PN short-code scrambler is multiplied by a complex PN sequence ($I_{PN} + j Q_{PN}$). This is also called 'quadrature spreading'. With channels of the radio configurations 1 and 2, whose generation is comparable with that of IS-95 systems, this block splits up the input stream in I and Q components.

The base-station-specific parameter PN offset determines the start phase of these PN short-code sequences. This permits signals of different base stations to be distinguished.

Generator polynomial for I and Q components of the PN short code:

$$P_I(x) = x^{15} + x^{13} + x^9 + x^8 + x^7 + x^5 + 1$$

$$P_Q(x) = X^{15} + x^{12} + x^{11} + x^{10} + x^6 + x^5 + x^4 + x^3 + 1$$

The period of a PN short-code sequence is 26.666 ms.

3.9 Spreading - Uplink

Increasing the data rate or spreading in the reverse link is performed in different ways depending on the radio configuration and the channel type.

3.9.1 Variable Length Walsh Spreading

Walsh codes with a variable spread factor are used for spreading. The spreading factor and the Walsh code depend on the spreading rate, channel type, frame length and the data rate. Spreading is obtained by multiplication of the input symbol (modulo 2 multiplication) by the real Walsh code.

3.9.2 64-Ary Orthogonal Modulator

Groups of 6 input bits are used for addressing a line of the Walsh code table with the spread code length of 64. This 'modulator' increases the data rate by a factor of 64/6. This type of rate increase comes from IS-95 and is used in the radio configurations 1 and 2.

3.10 Scrambling - Uplink

In the scrambling block of the uplink system, the spread data stream is scrambled by means of the long code and the PN short code. Different methods are used for the radio configurations 1, 2 and RC3 to RC5.

3.10.1 Scrambling for Radio Configuration 1 and 2

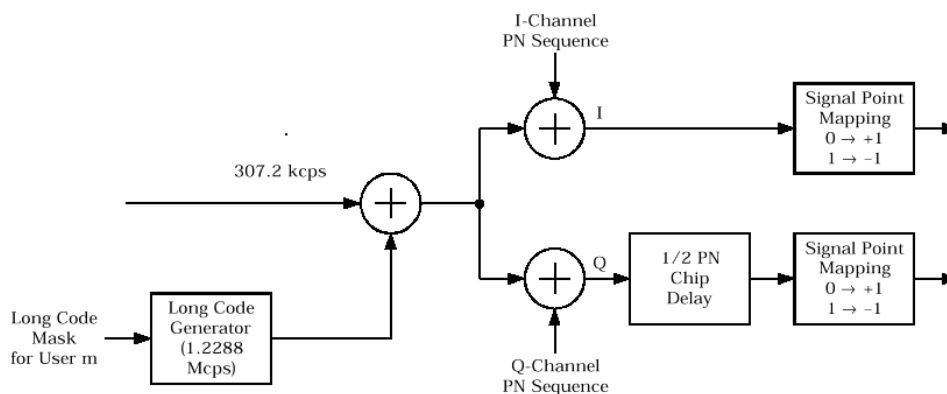

Figure 3-4: Scrambling in the uplink RC 1 and RC2

The output data stream of the spreading block is scrambled with the **long code**. The rate is increased in addition by a factor of four. The long-code generator is also referred to as scrambling code generator since it scrambles the chip sequence in a user-specific way (long-code mask). This generator exactly corresponds to the generation described in [Chapter 3.5, "Long-Code Scrambling Generator - Downlink"](#), on page 14 for the downlink.

The real input data stream of the **PN short-code** scrambler is multiplied by a complex PN sequence ($I_{PN} + j Q_{PN}$). This procedure is also called 'quadrature spreading'. With

channels of the radio configurations 1 and 2, whose generation is comparable with that of IS-95 systems, this block splits up the input stream in I and Q components.

In contrast to the downlink, no variable PN offset parameter is available for the PN short code in the reverse link. The PN offset is always 0.

Different generation rules are used for the PN short codes depending on the mode and spreading rate. The generator polynomials of the PN short codes correspond to the polynomials in the downlink (see [Chapter 3.8, "PN Short-Code Scrambling - Downlink"](#), on page 15). The I and Q data streams consisting of {0, 1} sequences are then mapped to {+1, -1} in the **signal point mapping** block.

Because of the delay of the Q component, offset QPSK constellation known from the reverse link of IS-95 is obtained from the QPSK constellation. Due to the Q delay, the transfer of the I and Q signal components from one chip to the next is never synchronous. For this reason, there are no zero crossings in the transfer from one chip to the next. This behavior can be seen in the vector diagram below.

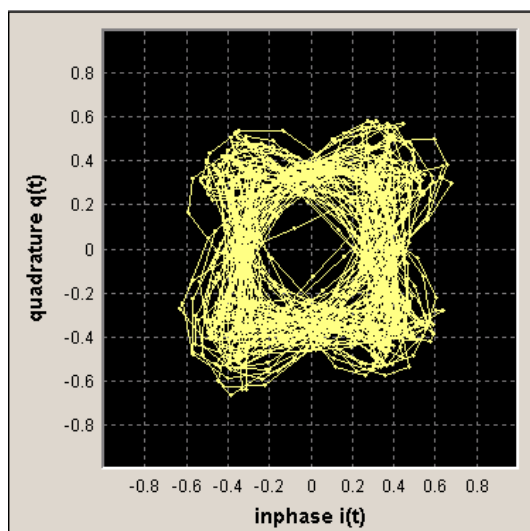

Figure 3-5: Scrambling in the uplink RC 1 and RC2

3.10.2 Scrambling for Radio Configuration 3, 4 and 5

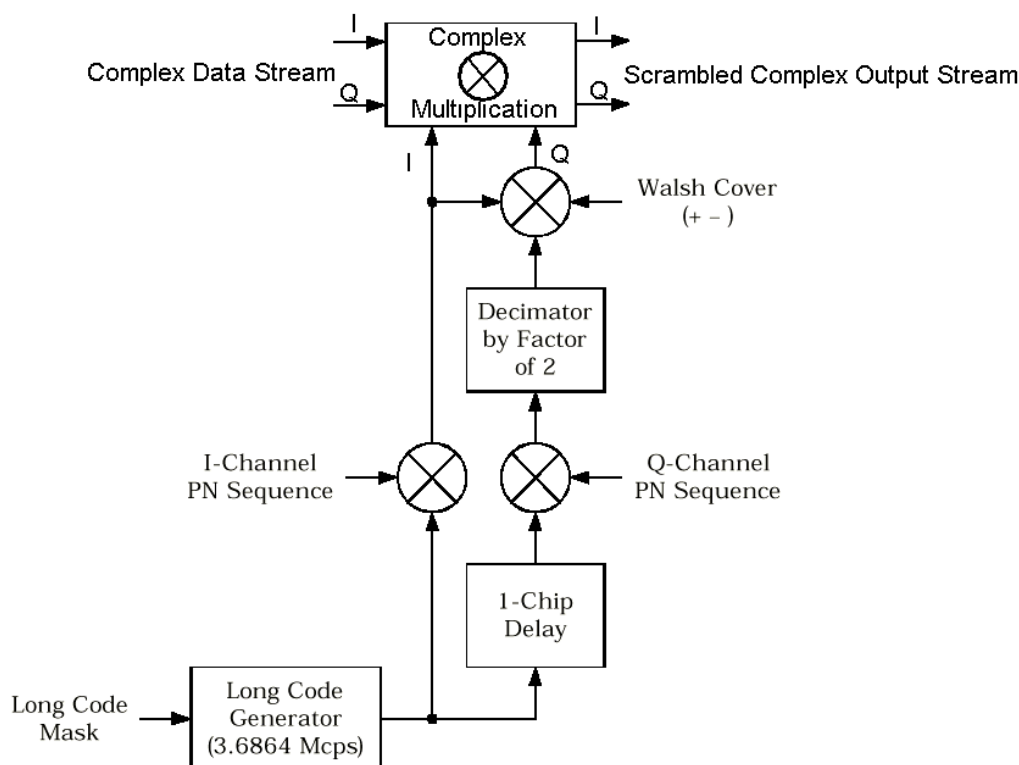

Figure 3-6: Scrambling in the uplink RC3, RC4 and RC5

Here too, the long-code generator defined in [Chapter 3.5, "Long-Code Scrambling Generator - Downlink"](#), on page 14 for the downlink is used. A complex long-code sequence is required. For this purpose, the output sequence of the generator is used as the I component and the sequence delayed by one chip as the Q component.

The I component of the long code is then multiplied by the I component of the PN short code. The same applies for the Q component. The definition of the PN short code is given in [Chapter 3.8, "PN Short-Code Scrambling - Downlink"](#), on page 15.

The subsequent operations decimate by factor of 2 and link the Q component to the Walsh sequence (+-) and the I component. They serve for reducing the zero crossings of the I/Q signal at the end of the whole scrambling process. Thus a behavior similar to behavior in the uplink of 3GPP is obtained. It is also known as **HPSK** (hybrid phase shift keying).

The resulting I/Q output stream is obtained by complex multiplication (modulo 2) of the I/Q input sequence of the scrambler by the complex scramble sequence. The complex scramble sequence is obtained from the long code and the PN short code. The constellation obtained is a combination of QPSK and offset QPSK.

In this mode, the traffic data streams of a channel are mapped either to the I or to the Q path of the complex data stream (see [Figure 3-6](#)). With these so-called BPSK channels, the channel component at the scrambler input consists of a real or an imaginary

component. As can be seen in the table below, the constellation after complex scrambling is again at the angle bisector.

Table 3-1: Output combinations with BPSK channels

d(n) \ S-Code(n)	-1-j	-1+j	+1-j	+1+j
-1	+1+j	+1-j	-1+j	-1-j
+1	-1-j	-1+j	+1-j	+1+j
-j	-1+j	+1+j	-1-j	+1-j
+j	+1-j	-1-j	+1+j	-1+j

3.11 Baseband Filtering - Uplink and Downlink

This block performs baseband filtering (pulse shaping and band limiting) of the I/Q signal. In addition to the filters specified in the standard, the signal generator also provides equalizer filters with a better adjacent-channel leakage ratio.

3.12 I/Q Modulator - Uplink and Downlink

The I/Q modulator defined in the IS2000 standard differs from the definition in this implementation. The definition on which the implementation is based is used by virtually all digital communication standards, except IS95 and IS2000.

In the final step, the filtered IQ signal is modulated to the desired RF in a different way in the I/Q modulator:

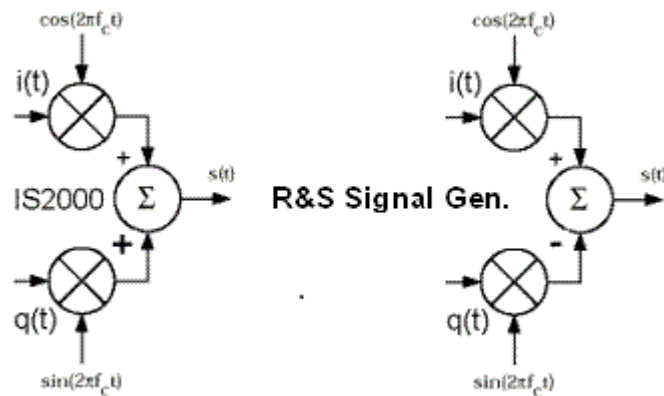

Figure 3-7: Definition of I/Q modulator in IS2000 and the R&S Signal Generator

IS2000 = the RF signal $s(t)$ is derived from the baseband I/Q signal as $s(t) = i(t)\cos(2\pi f_c t) + q(t)\sin(2\pi f_c t)$

R&S SMx/AMU = the RF signal $s(t)$ is based on the definition $s(t) = i(t)\cos(2\pi f_c t) - q(t)\sin(2\pi f_c t)$

To generate baseband signals according to IS2000 (CDMA200 standard) invert the Q-part of the signal, i.e. select "I/Q Modulator > I/Q Swap > On".

3.13 Constellation of I/Q Signals - Downlink

Depending on radio configuration and channel type, the signal components in the different channels create different subconstellations.

3.13.1 BPSK channels

With some channel types (in RC1/2 and in the pilot channel), the data stream is split up in I and Q components in the **PN short code scrambling** block. The input data stream of this block is a real +/-1 sequence similar to BPSK. The complex output data sequence is then as follows:

$$S_{out}(n) = d_{in}(n) (PN_I(n) + j PN_Q(n)), \text{ with } d_{in}(n), PN_I(n), PN_Q(n) \in \{-1, +1\}.$$

This yields four different output combinations for S_{out} :

$$(-1 -j), (-1 +j), (+1 -j), (+1 +j),$$

i.e. all points are on one of the two angle bisectors at the I/Q level.

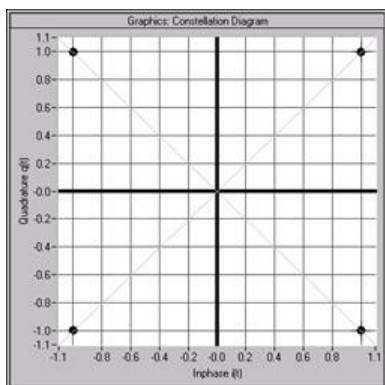

Figure 3-8: Constellation diagram of a BPSK channel with 0 dB power

3.13.2 QPSK channels

With other channel types, the input data stream of the **PN short code scrambling** block is a complex $\pm 1 \pm j$ sequence similar to QPSK. The complex output data sequence is then as follows:

$$S_{out}(n) = (d_I(n) + j d_Q(n)) (PN_I(n) + j PN_Q(n)), \text{ with } d_I(n), d_Q(n), PN_I(n), PN_Q(n) \in \{-1, +1\}.$$

Table 3-2: Output combinations with QPSK channels

PN(n) \ d(n)	-1-j	-1+j	+1-j	+1+j
-1-j	+2j	+2	-2	-2j
-1+j	+2	-2j	+2j	-2
+1-j	-2	+2j	-2j	+2
+1+j	-2j	-2	+2	+2j

This again yields four different output combinations for S_{out} :

$-2j, 2j, -2, 2,$

i.e. all points are on one of the two axes at the I/Q level.

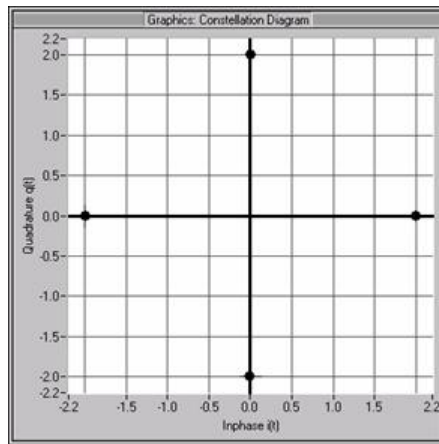
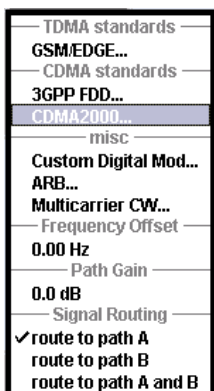

Figure 3-9: Constellation diagram of a QPSK channel with 0 dB power

3.14 Power Control - Downlink and Uplink

After spreading and scrambling, a channel-specific power factor p is applied to the signal. For example, a value of -6 dB therefore results in half the level (or $1/4$ power).

4 User Interface



The dialog for setting the CDMA2000 digital standard is either called from the base-band block or from the dialog tree under Baseband.

The dialog is split into several sections for configuring the standard. The choice of transmission direction determines which displays and parameters are made available in the lower section.

The upper section of the dialog is where the CDMA2000 digital standard is enabled, the default settings are called and the transmission direction selected.

The valid CDMA2000 version and the spreading rate in use are displayed.

Many of the buttons lead to subdialogs for loading and saving the CDMA2000 configuration and for setting the filter, trigger and clock parameters.

The lower dialog section is where either the base station signal or the mobile station signal is configured, depending on the transmission direction selected.

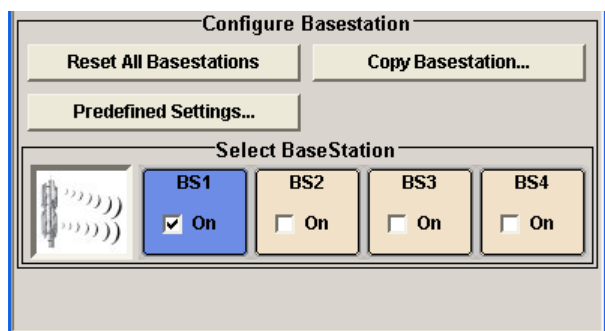
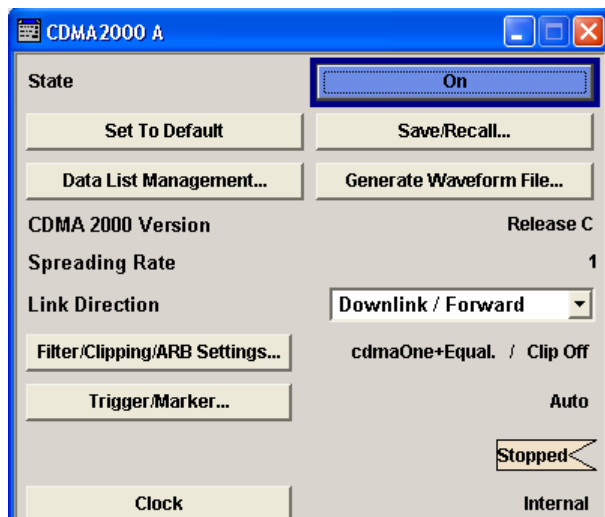

4.1 General Settings for CDMA2000 Signals

The upper dialog section is where the CDMA2000 digital standard is enabled and reset and where all the settings valid for the signal in both transmission directions are made.

State

Activates the standard and deactivates all the other digital standards and digital modulation modes in the same path.

Remote command:

[:SOURce<hw>] :BB:C2K:STATe on page 92

Set to Default

Calls the default settings. The values of the main parameters are listed in the following table.

Parameter	Value
State	Not affected by "Set to default"
Link Direction	Downlink
Filter	CdmaOne + Equalizer
Clipping	Off
Trigger	Auto
Clock	Internal
Base Station Configuration	
State	Off
Radio Configuration Traffic Channels 1 and 2	RC3
Radio Configuration other Traffic Channels	RC1
Time Delay	0 chips
PN Offset	0
Transmit Diversity	Off
Quasi Orthogonal Walsh Set	1
Mobile Station Configuration	
State	Off
Mode	Traffic
Radio Configuration	RC3
Channel Coding	Complete
LC Mask (hex)	0
State (all Channels)	Off
Power Control	Off

Remote command:

[:SOURce<hw>] :BB:C2K:PRESet on page 90

Save/Recall ...

Calls the "Save/Recall" dialog.

From the Save/Recall dialog, the "File Select" windows for saving and recalling CDMA2000 configurations and the "File Manager" can be called.



CDMA2000 configurations are stored as files with the predefined file extension * .cdma2k. The file name and the directory they are stored in are user-definable.

The complete settings in the "CDMA2000" dialog are saved and recalled.

"Recall CDMA2000 Setting"

Opens the File Select window for loading a saved CDMA2000 configuration.

The configuration of the selected (highlighted) file is loaded by pressing the "Select" button.

"Save CDMA2000 Setting"

Opens the "File Select" window for saving the current CDMA2000 signal configuration.

The name of the file is specified in the File name entry field, the directory selected in the save into field. The file is saved by pressing the "Save" button.

The "Fast Save" checkbox determines whether the instrument performs an absolute or a differential storing of the settings. Enable this function to accelerate the saving process by saving only the settings with values different to the default ones. "Fast Save" is not affected by the "Preset" function.

"File Manager"

Calls the "File Manager".
The "File Manager" is used to copy, delete and rename files and to create directories.

Remote command:

[:SOURce<hw>] :BB:C2K:SETTING:CATalog? on page 90

[:SOURce<hw>] :BB:C2K:SETTING:LOAD on page 91

[:SOURce<hw>] :BB:C2K:SETTING:STORE on page 91

[:SOURce<hw>] :BB:C2K:SETTING:STORE:FAST on page 92

[:SOURce<hw>] :BB:C2K:SETTING:DElete on page 91

Data List Management

Calls the "Data List Management" dialog. This dialog is used to create and edit a data list.

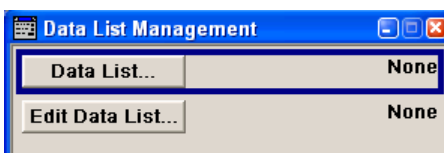

All data lists are stored as files with the predefined file extension *.dm_iqd. The file name and the directory they are stored in are user-definable.

The data lists must be selected as a data source from the subdialogs under the individual function, e.g. in the channel table of the base stations.

Note: All data lists are generated and edited by means of the `SOURCE:BB:DM` subsystem commands. Files containing data lists usually end with *.dm_iqd. The data lists are selected as a data source for a specific function in the individual subsystems of the digital standard.

Example: Creating and editing the data list

```
:SOUR:BB:DM:DLIS:SEL "d_list1"
:SOUR:BB:DM:DLIS:DATA #B1111010101000001111....
:SOUR:BB:DM:DLIS:DATA:APP #B1111010101000001111....
```

Remote command:

[\[:SOURCE<hw>\]:BB:C2K:BSTation<st>:CGRoup<di0>:COFFset<ch>:DATA](#)
on page 121

[\[:SOURCE<hw>\]:BB:C2K:BSTation<st>:CGRoup<di0>:COFFset<ch>:DATA:DSElect](#)
on page 122

[\[:SOURCE<hw>\]:BB:C2K:BSTation<st>:CGRoup<di0>:COFFset<ch>:TPC:DATA](#)
on page 128

[\[:SOURCE<hw>\]:BB:C2K:BSTation<st>:CGRoup<di0>:COFFset<ch>:TPC:DATA:DSElect](#)
on page 128

[\[:SOURCE<hw>\]:BB:C2K:MSTation<st>:CHANnel<ch>:DATA](#) on page 147

[\[:SOURCE<hw>\]:BB:C2K:MSTation<st>:CHANnel<ch>:DATA:DSElect](#)
on page 148

[\[:SOURCE<hw>\]:BB:C2K:MSTation<st>:TPC:DATA](#) on page 154

[\[:SOURCE<hw>\]:BB:C2K:MSTation<st>:TPC:DATA:DSElect](#) on page 154

Generate Waveform File

Opens the subdialog for storing the current CDMA2000 signal as ARB signal in a waveform file. This file can be loaded in the ARB dialog and processed as multicarrier or multisegment signal.

The file name is entered in the subdialog. The file is stored with the predefined file extension *.wv. The file name and the directory it is stored in are user-definable.

Remote command:

[\[:SOURCE<hw>\]:BB:C2K:WAVEform:CREate](#) on page 93

CDMA 2000 Version

Displays the current version of the CDMA2000 standard.

The default settings and parameters provided are oriented towards the specifications of the version displayed.

Remote command:

[\[:SOURCE\]:BB:C2K:VERSion?](#) on page 93

Spreading Rate

Displays the spreading rate.

Mode Spreading Rate 1 ("Direct Spread 1X") is used:

The **Chip Rate** parameter which determines the rate of the spread symbols that is used for signal output, can be varied in the Filter, Clipping, ARB Settings dialog (see [Chapter 4.3, "Filter / Clipping / ARB Settings"](#), on page 31).

Remote command:

[:SOURce<hw>] :BB:C2K:CRATe? on page 88

Link Direction

Selects the transmission direction.

The settings of the base station or the mobile station are provided in the following dialog section in accordance with the selection.

"Downlink/ Forward Link"

The transmission direction selected is base station to mobile station.
The signal corresponds to that of a base station.

"Uplink/ Reverse Link"

The transmission direction selected is mobile station to base station.
The signal corresponds to that of a mobile station.

Remote command:

[:SOURce<hw>] :BB:C2K:LINK on page 89

Filtering/Clipping/ARB Settings

Calls the dialog for setting baseband filtering, clipping and the sequence length of the arbitrary waveform component. The current setting is displayed next to the button.

The dialog is described in [Chapter 4.3, "Filter / Clipping / ARB Settings"](#), on page 31.

Remote command:

n.a.

Trigger/Marker

Calls the dialog for selecting the trigger source, for configuring the marker signals and for setting the time delay of an external trigger signal (see [Chapter 4.4, "Trigger/Marker/Clock Settings"](#), on page 35).

The currently selected trigger source is displayed to the right of the button.

Remote command:

n.a.

Execute Trigger

Executes a trigger manually. A manual trigger can be executed only when an internal trigger source and a trigger mode other than "Auto" have been selected.

Remote command:

[:SOURce<hw>] :BB:C2K:TRIGger:EXECute on page 99

Clock

Calls the dialog for selecting the clock source and for setting a delay (see [Chapter 4.4, "Trigger/Marker/Clock Settings"](#), on page 35).

Remote command:
n.a.

4.2 Configure Base Station or Mobile Station

Depending on the transmission direction selection, the central section of the dialog provides the "Configure Base Station" section or the "Configure Mobile Station" section.

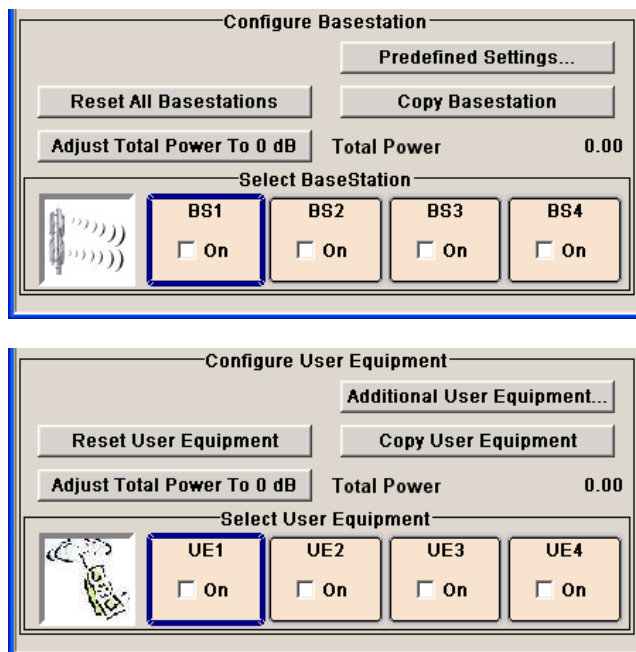

Reset All Base Stations

Resets all base stations to the predefined settings. The following table gives an overview of the settings. The preset value for each parameter is specified in the description of the remote-control commands.

Parameter	Value
Base Station Configuration	
State	Off
Time Delay	0 chips
PN Offset	0
Transmit Diversity	Off
Quasi-orthogonal Walsh set	1
State (all channels)	Off
Frame Length (0-5 / 0-7/ 0-10)	26.6 ms / 40 ms / 5 ms
Frame Length (all other channels)	20 ms

Parameter	Value
Data Rate (0-6,0-10,0-11,1-1,1-4,2-1,2-4)	9.6 kbps
Data Rate (0-7,0-9,1-2,1-3,2-2,2-3)	19.2 kbps
Data Rate (all other channels)	1.2 kbps
Walsh (0-2 / 0-5)	16 / 32
Walsh (1-1 / 1-2 / 1-3 / 2-1 / 2-2 / 2-3)	8 / 17 / 18 / 9 / 19 / 20
Walsh (all other channels)	0
Power (0-1 / 0-6)	-7 dB / -6.62 dB
Power (0-5 , 1-1, 2-1 / 1-2, 1-3, 2-2, 2-3)	-12.72 dB / -9.72 dB
Power (all other channels)	0 dB
Data Source (0-1, 0-2, 0-3, 0-4)	All0
Data Source (all other channels)	PN9
Channel Coding (all Channels)	Complete

Remote command:

[:SOURce<hw>] :BB:C2K:BSTation:PRESet on page 114

Reset All Mobile Stations

Resets all mobile stations to the predefined settings. The following table gives an overview of the settings. The preset value for each parameter is specified in the description of the remote-control commands.

Parameter	Value
Mobile Station Configuration	
State	Off
Mode	Traffic
Radio Configuration	3
Channel Coding	Complete
LC Mask (hex)	0
State (all Channels)	Off
Frame Length	20 ms
Data Rate (2 / 3, 4, 5)	9.6 kbps / 1.5 kbps
Walsh (0 / 8 / 4 / 2 / 6)	0 / 8 / 4 / 2 / 6
Spread (2 / 3, 4, 5)	32 / 16
Power	0 dB
Data Source	PN9

Remote command:

[:SOURce<hw>] :BB:C2K:MSTation:PRESet on page 146

Copy ...

Copies the settings of a base or mobile station to a second base or mobile station. A window opens for creating the destination station.

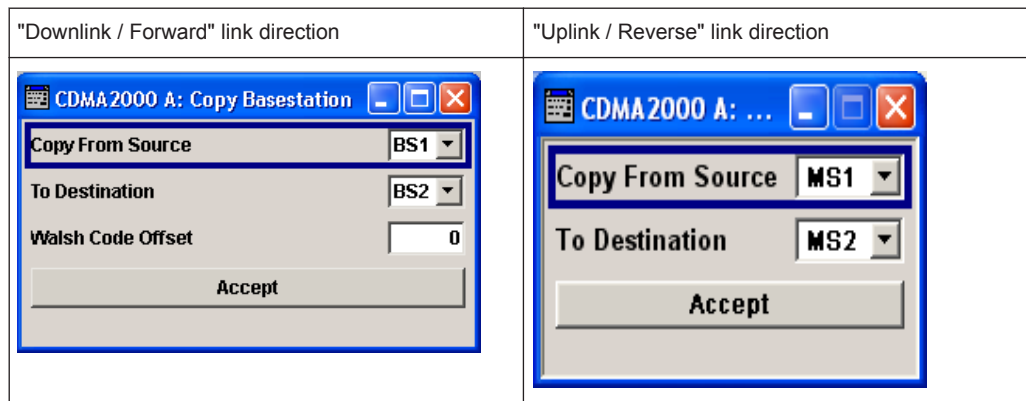

"Copy from Source"

Selects the base station or mobile station whose settings are to be copied.

"To Destination"

Selects the base station or mobile station whose settings are to be overwritten.

"Walsh Code Offset (Base Station only)"

Enters the offset to be applied when copying the base station to the Walsh codes of the destination base station. The minimum value is 0 (Walsh codes are identical), the maximum value is 255.

"Accept"

Starts the copy process.

Remote command:

[:SOURce<hw>] :BB:C2K:COPY:SOURce on page 88

[:SOURce<hw>] :BB:C2K:COPY:DESTInation on page 87

[:SOURce<hw>] :BB:C2K:COPY:COFFset on page 87

[:SOURce<hw>] :BB:C2K:COPY:EXECute on page 87

Predefined Settings

Accesses the dialog for setting predefined configurations in "Downlink / Forward" direction, see [Chapter 4.5, "Predefined Settings - Downlink"](#), on page 44.

Additional Mobile Station

Accesses the dialog for simulating up to 64 additional mobile stations, see [Chapter 4.6, "Additional Mobile Station - Uplink"](#), on page 47.

Adjust Total Power to 0dB

Sets the power of an enabled channel so that the total power of all the active channels is 0 dB. This does not change the power ratio among the individual channels.

This parameter is available when the "CDMA2000 > State > On".

Remote command:

[:SOURce<hw>] :BB:C2K:POWer:ADJust on page 90

Total Power

Displays the total power of the active channels.

The total power is calculated from the power ratio of the powered up code channels with modulation on. If the value is not equal to 0 dB, the individual code channels are internally adapted so that the "Total Power" for achieving the set output level is 0 dB. Power ratios between the channels are retained.

Remote command:

[:SOURce<hw>] :BB:C2K:POWer [:TOTal] ? on page 90

Select ...

Selects the base or mobile station and opens a dialog for editing the selected base or mobile station.

The dialogs are described in [Chapter 4.7, "Base Station Configuration"](#), on page 48 and [Chapter 4.10, "Mobile Station Configuration \(MS\)"](#), on page 76.

Remote command:

(the base station or mobile station is selected by the keyword index `BSStation<i>` or `MStation<i>`.)

Base Station/Mobile Station State

Activates a base or mobile station.

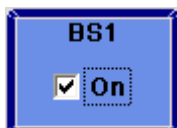

Remote command:

[:SOURce<hw>] :BB:C2K:BSStation<st>:STATe on page 142

[:SOURce<hw>] :BB:C2K:MStation<st>:STATe on page 154

4.3 Filter / Clipping / ARB Settings

- To access this dialog, select "Main dialog > Filter/Clipping/ARB Settings".

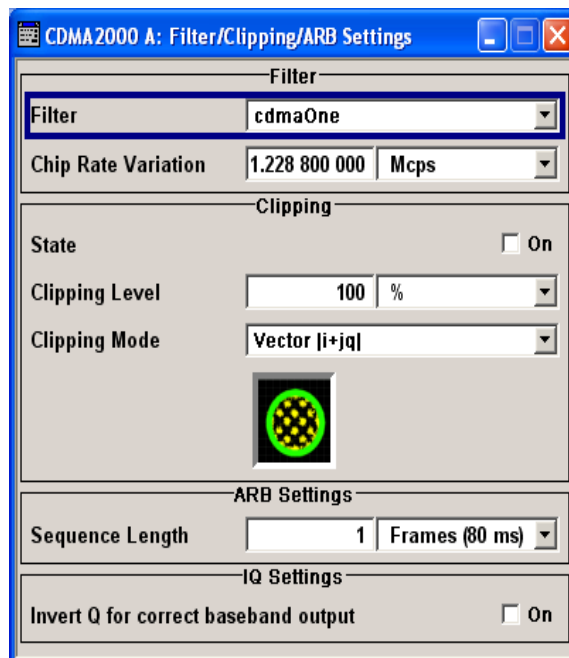

The dialog comprises the settings, necessary to configure the baseband filter, to enable clipping and adjust the sequence length of the arbitrary waveform component.

4.3.1 Filter Settings

Provided are the following settings:

Filter

Selects the baseband filter.

Remote command:

`[:SOURce<hw>] :BB:C2K:FILTer:TYPe` on page 94

Roll Off Factor or BxT

Sets the filter parameter.

The filter parameter ("Folloff Factor" or "BxT") depends on the currently selected filter type. This parameter is preset to the default for each of the predefined filters.

Remote command:

`[:SOURce<hw>] :BB:C2K:FILTer:PARAmeter:APCO25` on page 94

`[:SOURce<hw>] :BB:C2K:FILTer:PARAmeter:COSSine` on page 94

`[:SOURce<hw>] :BB:C2K:FILTer:PARAmeter:GAUSSs` on page 94

`[:SOURce<hw>] :BB:C2K:FILTer:PARAmeter:PGAuss` on page 95

[:SOURce<hw>] :BB:C2K:FiLTer:PARAmeter:RCOSine on page 96

[:SOURce<hw>] :BB:C2K:FiLTer:PARAmeter:SPHase on page 96

Cutoff Frequency Factor

Sets the value for the cutoff frequency factor. The cutoff frequency of the filter can be adjusted to reach spectrum mask requirements.

Remote command:

[:SOURce<hw>] :BB:C2K:FiLTer:PARAmeter:LPASs on page 95

[:SOURce<hw>] :BB:C2K:FiLTer:PARAmeter:LPASSEVM on page 95

Chip Rate Variation

Enters the chip rate.

Remote command:

[:SOURce<hw>] :BB:C2K:CRATe:VARiation on page 89

4.3.2 Clipping Settings

Provided are the following settings for configuring clipping:

Clipping State

Switches baseband clipping on and off.

Baseband clipping is a simple and effective way of reducing the crest factor of the signal. Since clipping is done before to filtering, the procedure does not influence the spectrum. The EVM however increases.

CDMA signals can have high crest factors particularly with many channels and long sequences. High crest factors entail two basic problems:

- The nonlinearity of the power amplifier (compression) causes intermodulation which expands the spectrum (spectral regrowth).
- Since the level in the D/A converter is relative to the maximum value, the average value is converted with a relatively low resolution. This results in a high quantization noise.

Both effects increase the adjacent-channel power.

With baseband clipping, all the levels are limited to a settable value ("Clipping Level"). This level is specified as a percentage of the highest peak value.

Since clipping the signal not only changes the peak value but also the average value, the effect on the crest factor is unpredictable.

Example:

This example shows the effect of the Clipping on the crest factor for typical scenarios. The following pictures demonstrate the effect of clipping with vector mode ($|i+q|$), using a signal configuration with two active channels.

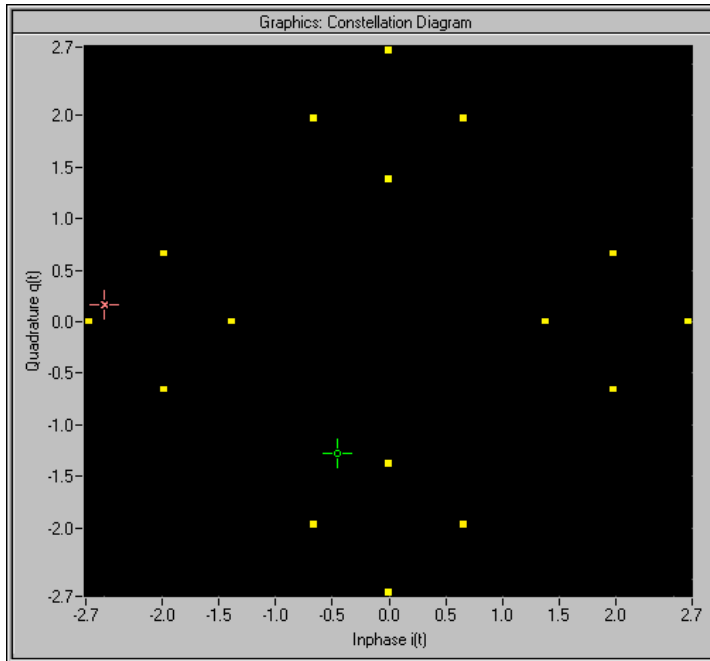

Figure 4-1: Constellation diagram of the signal without clipping, shows the level mapping .

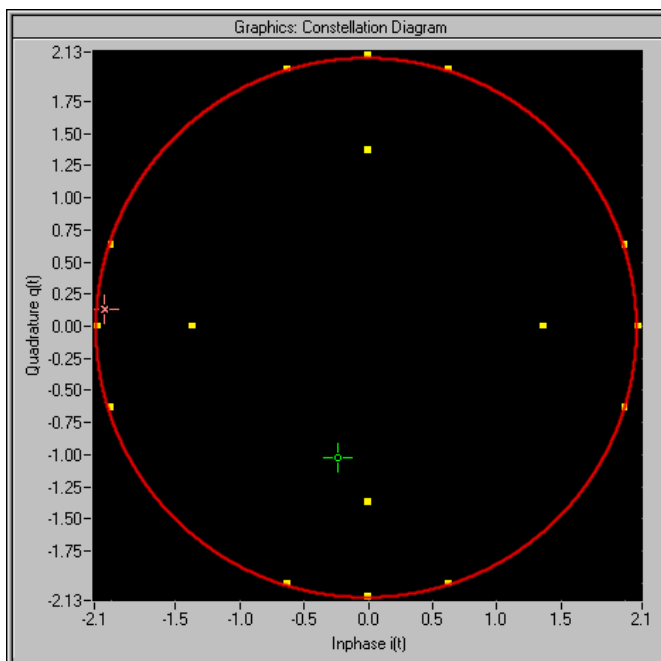

Figure 4-2: Constellation diagram with clipping level 80 %, vector mode ($|i+q|$) The circle emphasizes the changed constellation points.

Remote command:

[\[:SOURCE<hw>\]:BB:C2K:CLIPPING:STATE](#) on page 97

Clipping Level

Sets the limit for clipping.

This value indicates at what point the signal is clipped. It is specified as a percentage, relative to the highest level. 100% indicates that clipping does not take place.

Remote command:

[\[:SOURCE<hw>\]:BB:C2K:CLIPPING:LEVEL](#) on page 96

Clipping Mode

Selects the clipping method. A graphic illustration of the way in which this two methods work is given in the dialog.

- "Vector $|i + jq|$ "
The limit is related to the amplitude $|i + q|$. The I and Q components are mapped together, the angle is retained.
- "Scalar $|i|, |q|$ "
The limit is related to the absolute maximum of all the I and Q values $|i| + |q|$. The I and Q components are mapped separately, the angle changes.

Remote command:

[\[:SOURCE<hw>\]:BB:C2K:CLIPPING:MODE](#) on page 97

4.3.3 ARB Settings

Provided are the following settings for configuring the ARB settings:

Sequence Length ARB

Changes the sequence length of the arbitrary waveform component of the signal. This component is calculated in advance and output in the arbitrary waveform generator.

The number of chips is determined from this sequence length (1 Frame = 80 ms) and the chip rate. At 1.2288 MChips/s, a frame equals 98.304 chips.

In pure amplifier tests with several channels and no realtime channels, it is possible to improve the statistical properties of the signal by increasing the sequence length.

Note: Unlike for 3GPP, in the case of CDMA2000 the length of a frame is not uniformly defined. This implementation uses a frame length of 80 ms. Division into 80 ms frames was chosen because in this time grid the frame lengths for both the SYNC channel, with its cycle duration of 26.67 ms, and all other channels work out to 5 ms, 10 ms, 20 ms or 80 ms. The F-BCH has a frame length of 160 ms. In order to use this channel, an even number of 80 ms frames has to be set.

Remote command:

[\[:SOURCE<hw>\]:BB:C2K:SELENGTH](#) on page 92

4.3.4 I/Q Setting

Provided are the following settings for configuring the IQ settings:

Invert Q for Correct Baseband Output

Inverts Q-part of the baseband signal, see [Chapter 3.12, "I/Q Modulator - Uplink and Downlink"](#), on page 19.

With its default CDMA2000 settings, the R&S Signal Generator generates a standard compliant *RF* signal.

If a standard compliant *baseband* signal is required, enable this parameter to invert the Q-part of the baseband signal.

If both, the RF signal and baseband signal have to be compliant with the CDMA2000 standard:

- Set "Invert Q for Correct Baseband Output > On"
- Set "I/Q Mod > I/Q Settings > I/Q Swap > On"

Remote command:

[:SOURce<hw>] :BB:C2K:IQSWap [:STATe] on page 89

4.4 Trigger/Marker/Clock Settings

To access this dialog, select "Main Menu > Trigger/Marker".

The "Trigger In" section is where the trigger for the signal is set. Various parameters are provided for the settings, depending on which trigger source - internal or external - is selected. The status of signal generation ("Running" or "Stopped") is indicated for all trigger modes.

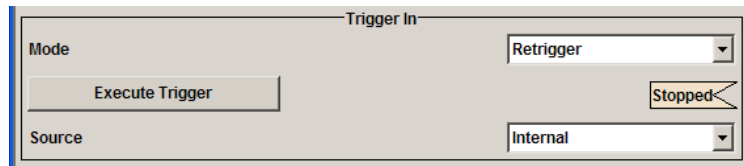

The "Marker Mode" section is where the marker signals at the MARKER output connectors are configured.

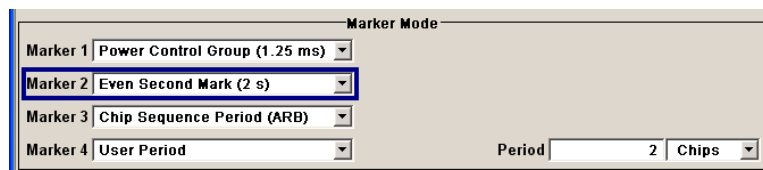

The "Marker Delay" section is where a marker signal delay can be defined, either without restriction or restricted to the dynamic range.

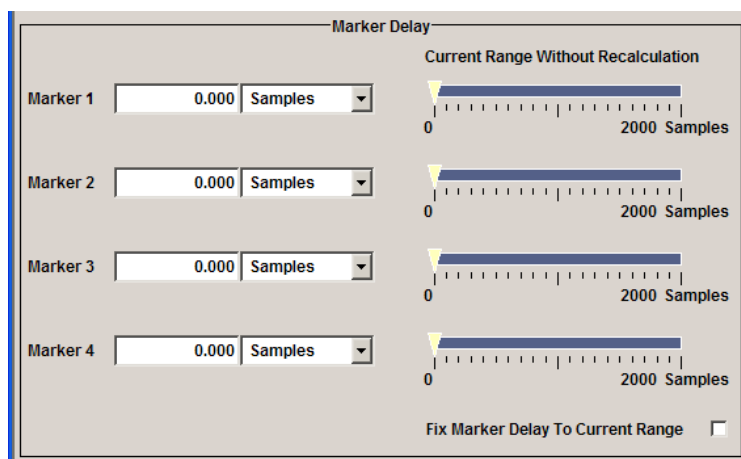

The "Clock Settings" section is where the clock source is selected and - in the case of an external source - the clock type.

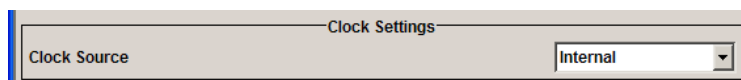

The buttons in the last section lead to subdialog for general trigger, clock and mapping settings.



4.4.1 Trigger In

The "Trigger In" section is where the trigger for the signal is set. Various parameters are provided for the settings, depending on which trigger source - internal or external - is selected. The status of signal generation ("Running" or "Stopped") is indicated for all trigger modes.

Trigger Mode

Selects trigger mode, i.e. determines the effect of a trigger event on the signal generation.

- "Auto"
The signal is generated continuously.
- "Retrigger"
The signal is generated continuously. A trigger event (internal or external) causes a restart.
- "Armed Auto"
The signal is generated only when a trigger event occurs. Then the signal is generated continuously.
An "Arm" stops the signal generation. A subsequent trigger event (internal with or external) causes a restart.
- "Armed Retrigger"

The signal is generated only when a trigger event occurs. Then the signal is generated continuously. Every subsequent trigger event causes a restart.

An "Arm" stops signal generation. A subsequent trigger event (internal with or external) causes a restart.

- "Single"
The signal is generated only when a trigger event occurs. Then the signal is generated once to the length specified at "Signal Duration".
Every subsequent trigger event (internal or external) causes a restart.

Remote command:

[\[:SOURCE<hw>\]:BB:C2K\[:TRIGGER\]:SEQUENCE](#) on page 98

Signal Duration Unit

Defines the unit for the entry of the length of the signal sequence to be output in the "Single" trigger mode. Available units are chip sequence length (CLS), chips or frames.

Remote command:

[\[:SOURCE<hw>\]:BB:C2K:TRIGGER:SLUNIT](#) on page 102

Signal Duration

Defines the length of the signal sequence to be output in the "Single" trigger mode.

It is possible to output deliberately just part of the signal, an exact sequence of the signal, or a defined number of repetitions of the signal.

Remote command:

[\[:SOURCE<hw>\]:BB:C2K:TRIGGER:SLLENGTH](#) on page 101

Running/Stopped

With enabled modulation, displays the status of signal generation for all trigger modes.

- "Running"
The signal is generated; a trigger was (internally or externally) initiated in triggered mode.
- "Stopped"
The signal is not generated and the instrument waits for a trigger event.

Remote command:

[\[:SOURCE<hw>\]:BB:C2K:TRIGGER:RMODE?](#) on page 101

Arm

Stops the signal generation until subsequent trigger event occurs.

Remote command:

[\[:SOURCE<hw>\]:BB:C2K:TRIGGER:ARM:EXECUTE](#) on page 99

Execute Trigger

Executes a trigger manually. A manual trigger can be executed only when an internal trigger source and a trigger mode other than "Auto" have been selected.

Remote command:

[\[:SOURCE<hw>\]:BB:C2K:TRIGGER:EXECUTE](#) on page 99

Trigger Source

Selects trigger source. This setting is effective when a trigger mode other than "Auto" has been selected.

- "Internal"
The trigger event is executed by "Execute Trigger".
- "Internal (Baseband A/B)"
(two-path instruments)
The trigger event is the trigger signal from the second path
- "External (Trigger 1/2)"
The trigger event is the active edge of an external trigger signal, supplied at the TRIGGER 1/2 connector.
Use the "Global Trigger/Clock Settings" dialog to define the polarity, the trigger threshold and the input impedance of the trigger signal.

Remote command:

[:SOURce<hw>] :BB:C2K:TRIGger:SOURce on page 99

Sync. Output to External Trigger

(enabled for "Trigger Source" External)

Enables/disables output of the signal synchronous to the external trigger event.

For R&S SMBV instruments:

For two or more R&S SMBV working in a master-slave mode, configure this parameter depending on the provided system trigger event and the properties of the output signal. See the table below for an overview of the required settings.

Table 4-1: Typical applications

System trigger	Application	"Sync. Output to External Trigger"
Common External Trigger event for the master and the slave instruments	All instruments are synchronous to the external trigger event	On
	All instruments are synchronous among themselves but starting the signal from first symbol is more important than synchronicity with external trigger event	Off
Internal trigger signal of the master R&S SMBV for the slave instruments	All instruments are synchronous among themselves	Off

"On"

Corresponds to the default state of this parameter.

The signal calculation starts simultaneously with the external trigger event but because of the instrument's processing time the first samples are cut off and no signal is outputted. After elapsing of the internal processing time, the output signal is synchronous to the trigger event.

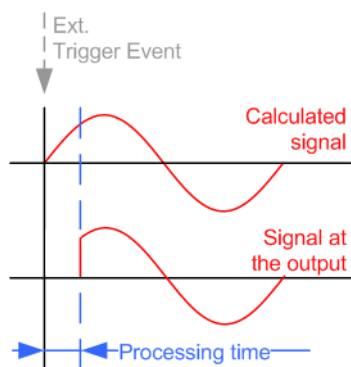

"Off"

The signal output begins after elapsing of the processing time and starts with sample 0, i.e. the complete signal is outputted.

This mode is recommended for triggering of short signal sequences with signal duration comparable with the processing time of the instrument.

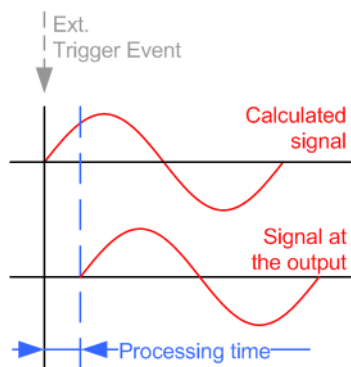

Remote command:

`[:SOURce<hw>] :BB:C2K:TRIGger:EXTernal:SYNChronize:OUTPut`
on page 99

Trigger Delay

Sets the trigger signal delay in samples on external triggering.

This enables the R&S Signal Generator to be synchronized with the device under test or other external devices.

For two-path instruments, the delay can be set separately for each of the two paths.

Remote command:

`[:SOURce<hw>] :BB:C2K:TRIGger [:EXTernal<ch>] :DELay` on page 100
`[:SOURce<hw>] :BB:C2K:TRIGger:OBASeband:DELay` on page 100

Trigger Inhibit

Sets the duration for inhibiting a new trigger event subsequent to triggering. The input is to be expressed in samples.

In the "Retrigger" mode, every trigger signal causes signal generation to restart. This restart is inhibited for the specified number of samples.

This parameter is only available on external triggering or on internal triggering via the second path.

For two-path instruments, the trigger inhibit can be set separately for each of the two paths.

Remote command:

[\[:SOURce<hw>\]:BB:C2K:TRIGger\[:EXTernal<ch>\]:INHibit](#) on page 101

[\[:SOURce<hw>\]:BB:C2K:TRIGger:OBASeband:INHibit](#) on page 100

4.4.2 Marker Mode

The marker output signal for synchronizing external instruments is configured in the "Marker Settings" section "Marker Mode".

The R&S SMBV supports only two markers.

Marker Mode

Selects a marker signal for the associated MARKER output.

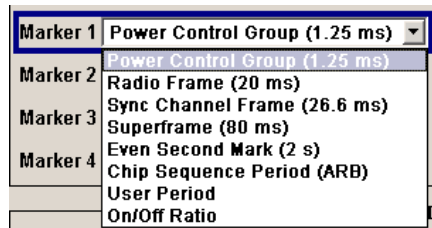

"Power Control Group (1.25 ms)" A marker signal is generated at the start of each Power Control group (every 1.25 ms).

"Radio Frame (20 ms)" A marker signal is generated every 20 ms (traffic channel frame clock).

"Sync Channel Frame (26.6 ms)" A marker signal is generated at the beginning of each Sync Channel Frame (every 26.6 ms).

"Superframe (80 ms)" A marker signal is generated every 80 ms (super frame clock).

"Even Second Mark (2 s)" A marker signal is generated every 2 seconds.

"Chip Sequence Period (ARB)" A marker signal is generated at the beginning of every arbitrary waveform sequence (depending on the set sequence length). The marker signal is generated regardless of whether an ARB component is used.

"ON/OFF Period" A regular marker signal that is defined by an on/off ratio is generated. A period lasts one on and off cycle.



The "ON Time" and "OFF Time" are each expressed as a number of samples and are set in an input field which opens when on/off ratio is selected.

Remote command:

`[:SOURce<hw>] :BB:C2K:TRIGger:OUTPut<ch>:ONTime` on page 104

`[:SOURce<hw>] :BB:C2K:TRIGger:OUTPut<ch>:OFFTime` on page 104

"User Period" A marker signal is generated at the beginning of every user-defined period. The period is defined in "Period".

Remote command:

`[:SOURce<hw>] :BB:C2K:TRIGger:OUTPut<ch>:PERiod` on page 104

Remote command:

`[:SOURce<hw>] :BB:C2K:TRIGger:OUTPut<ch>:MODE` on page 103

4.4.3 Marker Delay

The delay of the signals on the MARKER outputs is set in the "Marker Delay" section.

The R&S SMBV supports only two markers.

Marker x Delay

Enters the delay between the marker signal at the marker outputs and the start of the frame or slot.

The input is expressed as a number of symbols/samples.

If the setting "Fix marker delay to dynamic range" is enabled, the setting range is restricted to the dynamic range. In this range, the delay of the marker signals can be set without restarting the marker and signal.

Remote command:

`[:SOURce<hw>] :BB:C2K:TRIGger:OUTPut<ch>:DELay` on page 103

Current Range without Recalculation

Displays the dynamic range within which the delay of the marker signals can be set without restarting the marker and signal.

The delay can be defined by moving the setting mark.

Remote command:

`[:SOURce<hw>] :BB:C2K:TRIGger:OUTPut<ch>:DELay:MINimum?` on page 103

`[:SOURce<hw>] :BB:C2K:TRIGger:OUTPut<ch>:DELay:MAXimum?` on page 103

Fix marker delay to current range

Restricts the marker delay setting range to the dynamic range. In this range, the delay can be set without restarting the marker and signal.

Remote command:

[\[:SOURce<hw>\]:BB:C2K:TRIGger:OUTPut:DELAy:FIXed](#) on page 102

4.4.4 Clock Settings

The "Clock Settings" is used to set the clock source and a delay if necessary.

Sync. Mode

(for R&S SMBV only)

Selects the synchronization mode.

This parameter is used to enable generation of precise synchronous signal of several connected R&S SMBVs.

Note: If several instruments are connected, the connecting cables from the master instrument to the slave one and between each two consecutive slave instruments must have the same length and type.

Avoid unnecessary cable length and branching points.

"None" The instrument is working in standalone mode.

"Sync. Master" The instrument provides all connected instrument with its synchronization (including the trigger signal) and reference clock signal.

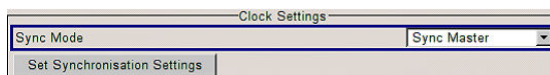

"Sync. Slave" The instrument receives the synchronization and reference clock signal from another instrument working in a master mode.

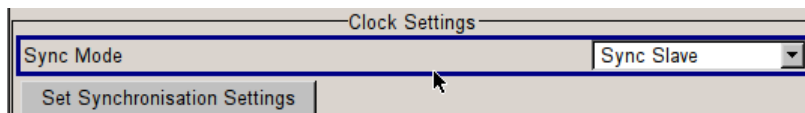

Remote command:

[\[:SOURce<hw>\]:BB:C2K:CLOCK:SYNChronization:MODE](#) on page 107

Set Synchronization Settings

(for R&S SMBV only)

Performs automatically adjustment of the instrument's settings required for the synchronization mode, selected with the parameter "Synchronization Mode".

Remote command:

[\[:SOURce<hw>\]:BB:C2K:CLOCK:SYNChronization:EXECute](#) on page 106

Clock Source

Selects the clock source.

"Internal" The internal clock reference is used to generate the symbol clock.

"External" The external clock reference is fed in as the symbol clock or multiple thereof via the CLOCK connector.
The symbol rate must be correctly set to accuracy of +/-2 % (see data sheet).
The polarity of the clock input can be changed with the aid of "Global Trigger/Clock Settings".
In the case of two-path instruments, this selection applies to path A.

Remote command:

[:SOURce<hw>] :BB:C2K:CLOCK:SOURce on page 106

Clock Mode

Enters the type of externally supplied clock.

"Chip" A chip clock is supplied via the CLOCK connector.

"Multiple" A multiple of the chip clock is supplied via the CLOCK connector; the chip clock is derived internally from it.
The "Multiplier" window provided allows the multiplication factor to be entered.

Remote command:

[:SOURce<hw>] :BB:C2K:CLOCK:MODE on page 105

Clock Multiplier

Enters the multiplication factor for clock type "Multiple".

Remote command:

[:SOURce<hw>] :BB:C2K:CLOCK:MULTiplier on page 105

Measured External Clock

Provided for permanent monitoring of the enabled and externally supplied clock signal.

Remote command:

CLOCK:INPut:FREQuency?

4.4.5 Global Settings

The buttons in this section lead to dialogs for general trigger, clock and mapping settings.

Global Trigger/Clock Settings

Calls the "Global Trigger/Clock/Input Settings" dialog.

This dialog is used among other things for setting the trigger threshold, the input impedance and the polarity of the clock and trigger inputs.

The parameters in this dialog affect all digital modulations and standards, and are described in chapter "Global Trigger/Clock/Input Settings" in the Operating Manual.

User Marker / AUX I/O Settings

Calls the "User Marker AUX I/O Settings" dialog, used to map the connector on the rear of the instruments.

See also "User Marker / AUX I/O Settings" in the Operating Manual.

4.5 Predefined Settings - Downlink

The "Predefined Settings" can be reached via the "CDMA2000" main dialog. It is only available when the Downlink transmission direction is selected.

In the top section of the dialog, the radio configuration of the test scenario and the used special channels are selected.

The channel table of base station 1 is filled (preset) with the set parameters.

With the "Predefined Settings" function, it is possible to create highly complex scenarios with just a few keystrokes. This function is of use if, say, just the envelope of the signal is of interest.

A separate set of settings of all predefined parameters is provided for each radio configuration. If the radio configuration is changed, the set of traffic channel settings belonging to this RC is automatically indicated.

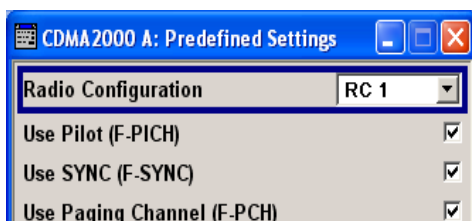

In the "Traffic Channel Settings" section, the number and the structure of the traffic channels used in the test scenario is set. The selected structure is valid for all activated traffic channels.

The indicated parameters depend on the radio configuration. Their settings are specific for the selected radio configuration.

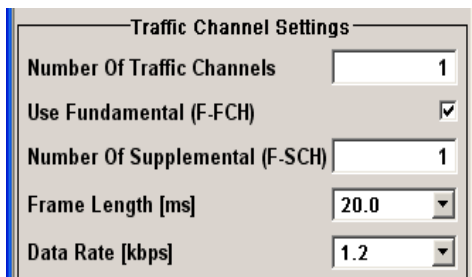

Additionally, the desired range for the crest factor is selected. Button "Accept" presets the channel table of base station 1 with the predefined parameters.



Radio Configuration - Predefined Settings

Selects the radio configuration (RC).

The R&S Signal Generator provides a separate set of settings of all predefined traffic channel parameters for each radio configuration. If the radio configuration is changed, the set of traffic channel table values belonging to this RC is automatically activated.

Remote command:

[\[:SOURCE<hw>\]:BB:C2K:PPARAmeter:RCONfiguration](#) on page 109

Use Pilot (F-PICH) - Predefined Settings

Selects if pilot channel F-PICH is used in the scenario or not.

Remote command:

[\[:SOURCE<hw>\]:BB:C2K:PPARAmeter:PIChannel\[:STATe\]](#) on page 109

Use Sync (F-Sync) - Predefined Settings

Selects if sync channel F-SYNC is used in the scenario or not.

Remote command:

[\[:SOURCE<hw>\]:BB:C2K:PPARAmeter:SCHannel\[:STATe\]](#) on page 109

Use Paging Channel (F-PCH) - Predefined Settings

Selects if paging channel F-PCH is used in the scenario or not.

Remote command:

[\[:SOURCE<hw>\]:BB:C2K:PPARAmeter:PChannel\[:STATe\]](#) on page 108

Number of Traffic Channels - Predefined Settings

Sets the number of activated traffic channels. Channels F-DCCH, F-FCH, and F-SCH form a traffic channel.

Remote command:

[\[:SOURCE<hw>\]:BB:C2K:PPARAmeter:TChannel:COUNT](#) on page 110

Use Dedicated Control (F-DCCH) - Predefined Settings

Selects if the dedicated control channel F-DCCH is activated for the traffic channel or not. PN9 is used as a data source for F-DCCH.

The set state is specific for the selected radio configuration.

F-DCCH cannot be activated for radio configuration RC1 and RC2.

Remote command:

[\[:SOURCE<hw>\]:BB:C2K:PPARAmeter:TChannel:DCChannel\[:STATe\]](#)
on page 111

Use Fundamental (F-FCH) - Predefined Settings

Selects if the fundamental channel F-FCH is activated for the traffic channel or not. PN9 is used as data source for F-FCH. The set value is specific for the selected radio configuration.

Remote command:

[\[:SOURCE<hw>\]:BB:C2K:PPARAmeter:TChannel:FChannel\[:STATe\]](#)
on page 111

Number of Supplemental (F-SCH) - Predefined Settings

Sets the number of activated supplemental channels F-SCH. PN9 is used as data source for F-SCH. The set value is specific for the selected radio configuration.

The maximum number depends on the selected radio configuration:

- RC1 and RC2: 0 ... 7
- RC3, RC4, and RC5: 0 ... 2

Remote command:

`[:SOURce<hw>] :BB:C2K:PPARameter:TCHannel:SCHannel:COUNT`

on page 112

Frame Length - Predefined Settings

Sets the frame length of the traffic channel. The set value is specific for the selected radio configuration.

The value range for the frame length depends on the selected radio configuration:

- RC1 and RC2: 20 ms
- RC3 to RC5: 5, 20, 40 ms and 80 ms

Remote command:

`[:SOURce<hw>] :BB:C2K:PPARameter:TCHannel:FLENgth` on page 111

Data Rate - Predefined Settings

Sets the data rate for F-FCH and all F-SCH. The set value is specific for the selected radio configuration.

The value range depends on the set frame length.

Remote command:

`[:SOURce<hw>] :BB:C2K:PPARameter:TCHannel:DATA:RATE` on page 110

Crest Factor - Predefined Settings

Selects the desired range for the crest factor of the test scenario. The crest factor of the signal is kept in the desired range by automatically setting appropriate Walsh Code Numbers.

"Minimum"	The crest factor is minimized by assigning Walsh codes which are chosen as close as possible.
"Average"	An average crest factor is set. The Walsh codes are distributed uniformly over the code domain.
"Worst"	The crest factor is set to an unfavorable value (i.e. maximum) by assigning Walsh codes which are separated as widely as possible.

Remote command:

`[:SOURce<hw>] :BB:C2K:PPARameter:CRESt` on page 108

Accept - Predefined Settings

Presets the channel table of base station 1 with the parameters defined in the "Predefined Settings" dialog. Base station one is switched on, the other base stations are switched off.

Remote command:

`[:SOURce<hw>] :BB:C2K:PPARameter:EXECute` on page 108

4.6 Additional Mobile Station - Uplink

Subdialog "Additional User Equipment" can be reached via the "CDMA2000" main dialog. It is only available when the Uplink transmission direction is selected.

It is possible to simulate up to 64 additional mobile stations and thus to generate a signal that corresponds to the received signal for a base station with high capacity utilization.

The fourth mobile station (MS4) serves as a template for all other stations. The following parameters are the only ones modified for the additional mobile stations:

- LC Mask Step (different for all stations)
- Power (different to MS4, but identical among themselves)

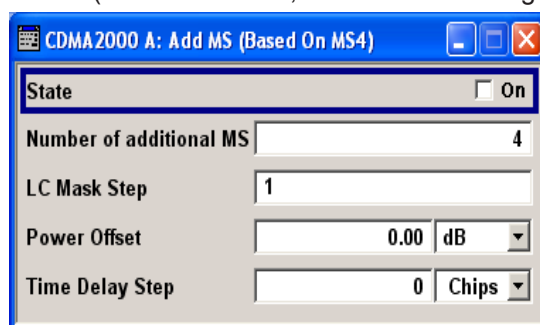

State

Activates additional mobile stations. At "State Off", all the additional mobile stations are switched off.

Remote command:

`[:SOURCE<hw>] :BB:C2K:MSTation:ADDITIONAL:STATE` on page 146

Number of Additional MS

Sets the number of additional mobile stations. As many as 64 additional mobile stations can be simulated.

Remote command:

`[:SOURCE<hw>] :BB:C2K:MSTation:ADDITIONAL:COUNT` on page 145

LC Mask Step

Enters the step width for increasing the LC mask of the additional mobile stations. The start value is the scrambling code of MS4.

The Long Code generator mask serves for channel-specific and user-specific scrambling of the code channel.

Remote command:

`[:SOURCE<hw>] :BB:C2K:MSTation:ADDITIONAL:LCMask:STEP` on page 145

Power Offset

Sets the power offset of the active channels of the additional mobile stations to the power outputs of the active channels of MS4.

The resultant power must fall within the range 0 ... - 80 dB. If the value is above or below this range, it is limited automatically.

Remote command:

`[:SOURce<hw>] :BB:C2K:MSTation:ADDITIONal:POWer:OFFSet` on page 145

Time Delay Step

Enters the step width for the time delay of the additional mobile stations to one another. The start value returns the time delay of MS4. Entry is made in chips and can be a maximum of one frame.

The time delay allows mobile stations to be simulated even if the arrival of their signals is not synchronized at the base station.

Remote command:

`[:SOURce<hw>] :BB:C2K:MSTation:ADDITIONal:TDELay:STEP` on page 146

4.7 Base Station Configuration

The "Base Station Configuration" dialog is called by selecting base station "BS1" ... "BS4" in the "CDMA2000" dialog. Base stations can be configured independently of one another.

The dialog comprises the "Common Settings" section, in which the general parameters of the base station are set, a row containing the buttons "Code Domain..." and "Channel Graph...", which calls the appropriate graphics and the most important part, the channel table.

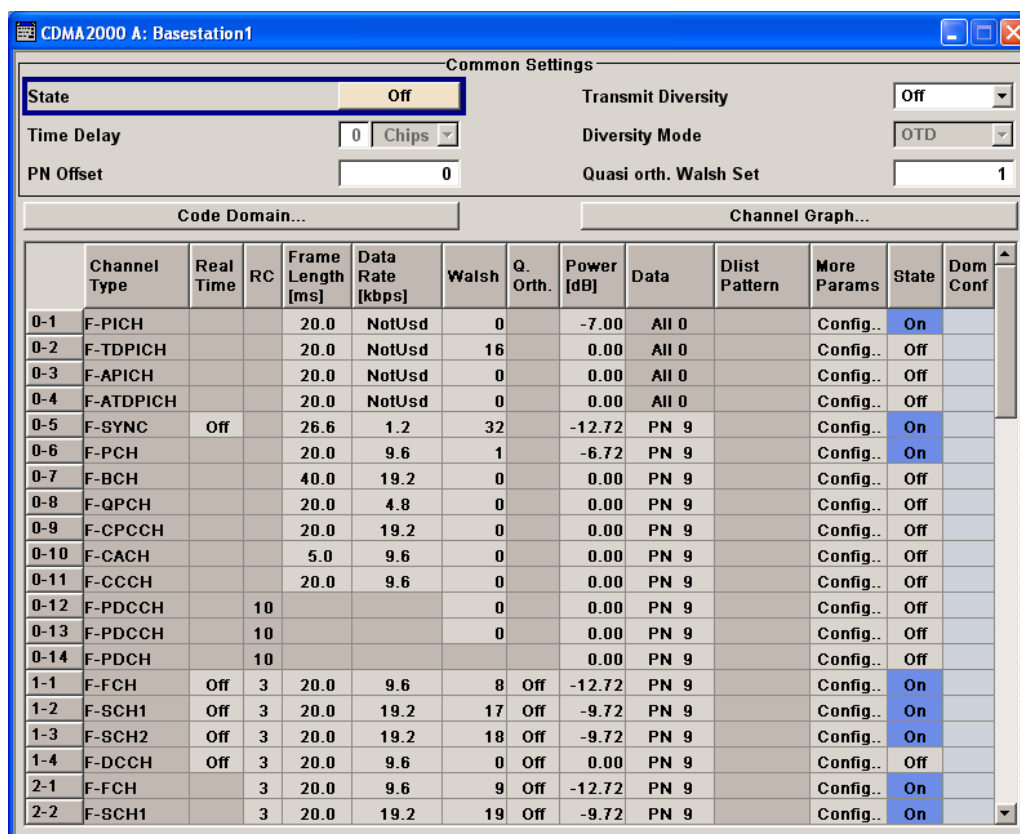

4.7.1 Common Settings

The general parameters of the base station are set in the "Common Settings" section.

State - BS

Activates or deactivates the selected base station.

Remote command:

`[:SOURce<hw>] :BB:C2K:BSTation<st>:STATe` on page 142

Transmit Diversity - BS

Switches transmit diversity on and off.

The signal can be sent simultaneously on several antennas. Various forms of transmit diversity are described in the CDMA2000 standard. Different coding is used to divide the signal between the two antennas. As a result, the receiver can decode the traffic signal from the two input signals and is less liable to fading and other interference. The R&S Signal Generator can simulate the signal of one of the two antennas.

To activate transmit diversity, the antennas whose signals are to be simulated must be specified. The signal is generated differently depending on the selected antenna.

Additionally two diversity schemes for the calculation of the signals are available for selection at "Diversity Mode".

"Off" No transmit diversity

"Antenna 1" Calculates and applies the output signal for antenna 1. The diversity scheme is selected at "Diversity Mode".

"Antenna 2" Calculates and applies the output signal for antenna 2. The diversity scheme is selected at "Diversity Mode".

Remote command:

`[:SOURce<hw>] :BB:C2K:BSTation<st>:TDIVersity` on page 143

Diversity Mode - BS

Selects the diversity scheme for "Transmit Diversity".

The diversity scheme defines the calculation mode of the signal for the selected antenna (at Transmit Diversity).

"OTD" Orthogonal Transmit Diversity Mode. A forward link transmission method which distributes forward link channel symbols among multiple antennas and spreads the symbols with a unique Walsh or quasi-orthogonal function associated with each antenna.

"STS" Space Time Spreading Mode. A forward link transmission method which transmits all forward link channel symbols on multiple antennas and spreads the symbols with complementary Walsh or quasi-orthogonal functions.

Remote command:

`[:SOURce<hw>] :BB:C2K:BSTation<st>:TDIVersity:MODE` on page 143

Time Delay - BS

Enters the time delay of the signal of the selected basestation compared to the signal of BS1.

Note: For BS1, this value is always 0 and read-only.

Remote command:

`[:SOURce<hw>] :BB:C2K:BSTation<st>:TDELay` on page 143

PN Offset - BS

Enters the PN offset (short code).

The PN offset determines the start phase of these PN short-code sequences (see [Chapter 3.8, "PN Short-Code Scrambling - Downlink"](#), on page 15).

This permits signals of different basestations to be distinguished.

Remote command:

`[:SOURce<hw>] :BB:C2K:BSTation<st>:PNOffset` on page 142

Quasi orth Walsh Set - BS

Selects the Quasi Orthogonal Walsh Set. The standard defines three different sets.

The so-called 'quasi-orthogonal Walsh sets' can be used in addition to the Walsh codes. They increase the number of possible channels and thus extend the basestation capacity. When the quasi-orthogonal Walsh code is used, spreading the data stream results in complex spreading also through an additional rotation of the output phase (the spreading code then consists of a real and an imaginary part).

Walsh codes of the lengths 4, 8, 16, 32, 64, and 128 are used in CDMA2000 with spreading rate 1. The greater the spreading factor / Walsh code length, the smaller the useful symbol rate prior to spreading and vice versa.

In contrast to the spreading codes of 3GPP, Walsh codes of short lengths (low spreading factor) do not occupy a block area in a Walsh matrix of larger spreading factor. Several lines (ratio of the two spreading factors) are occupied in the matrix with a higher spreading factor, distributed over the whole matrix. This behavior is illustrated in the diagram below. This results from the structuring scheme of the Walsh codes that are obtained by copying and inverting the next smaller matrix.

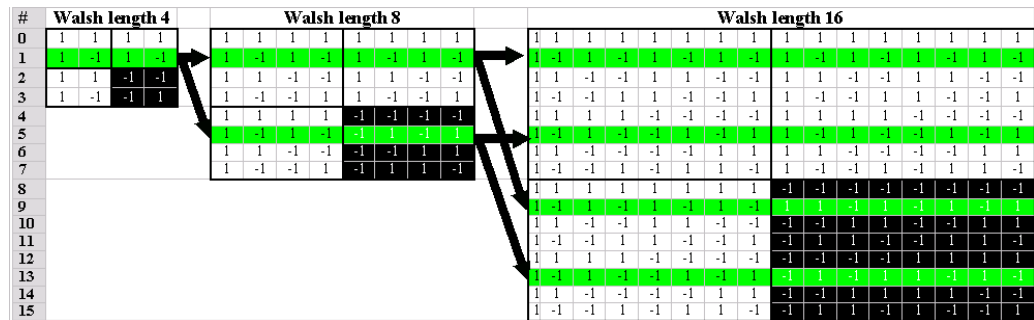

Figure 4-4: Walsh code tree

If a Walsh code with the length 4 and index 1 is used, codes 1 and 5 are disabled at the length 8, and codes 1, 5, 9 and 13 at the length 16 because codes of greater length contain the output code of shorter length (or its inversion).

When using such conflicting Walsh codes simultaneously, the signals of the associated code channels are mixed so that they can no longer be separated in the receiver. Orthogonality then is lost.

The matrix range with the highest spreading factor (i.e. 128), which is based on the spreading code selected in the code tree, is then defined as domain of a specific Walsh spreading code. Using a spreading code means that its entire domain is used.

The "Code Domain" graphic shows the assignment of active code channels in the code domain. The upper part shows the code domain of the standard Walsh set, the lower part the code domain of quasi-orthogonal Walsh sets.

The code numbers are plotted on the X axes, the colored bars show the code channels. The legend at the left of the graph indicates the assignment of colors to the spreading factors. An additional color is reserved for the packet channel F-PDCH because this channel can be assigned to more than one code channel. The height of the bars indicates the power of the code channel.

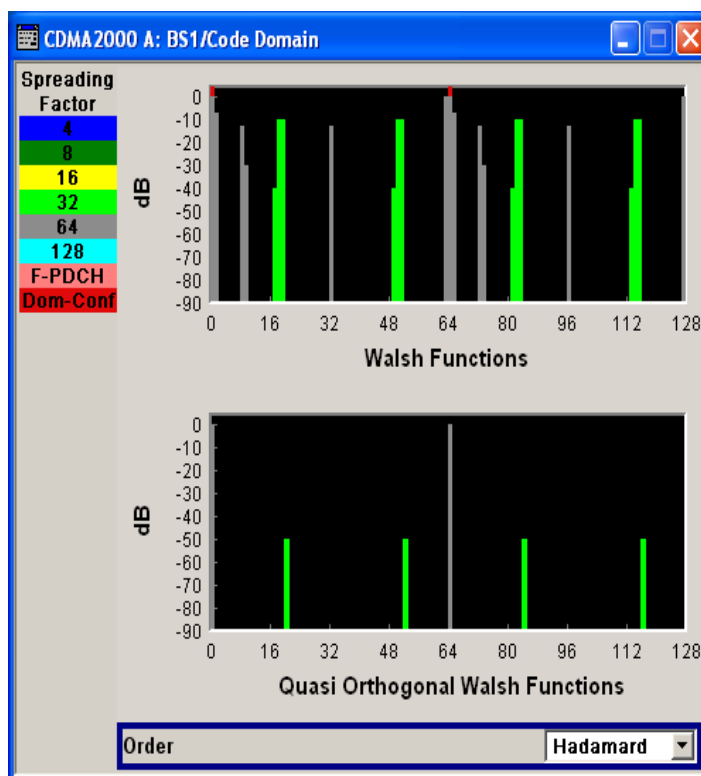

In this display assignment of the domains can be seen at a glance. Compared to 3GPP it is however much more difficult to see whether the code domains of different channels overlap, i.e. whether there is a domain conflict. This is due to the structure of the Walsh codes described above. The reason is that no block areas are occupied in the domain but several areas of minimum width are distributed over the whole domain.

Therefore, the occurrence of a domain conflict is indicated by a red dot marking of the involved channels. In addition, in the channel table, a code domain conflict is indicated in the column "Dom Conf" on the far right of the graph by a red dot and the orange-colored column.

	Channel Type	Real Time	RC	Frame Length [ms]	Data Rate [kbps]	Walsh	Q. Orth.	Power [dB]	Data	Dlist Pattern	More Params	State	Dom Conf
14	F-PDCH		10					0.00	PN 9		Config..	Off	
31	F-FCH	Off	4	20.0	9.6	0	Off	0.00	PN 9		Config..	Off	
32	F-SCH31	Off	4	20.0	9.6	0	On	0.00	PN 9		Config..	On	●
33	F-SCH32	Off	4	20.0	9.6	1	Off	0.00	PN 9		Config..	On	●
34	F-DCCH	Off	4	20.0	9.6	2	Off	0.00	PN 9		Config..	On	
41	F-FCH		5	20.0	14.4	3	Off	0.00	PN 9		Config..	On	●



The graph is calculated from the settings that have been made. A change in the settings results at once in a change of the graphical display.

Order - Code Domain BS

Switches the order of the spreading codes.

- "Hadamard" The code channels are displayed in the order determined by the Hadamard matrix. The codes are numbered as Walsh codes according to the standard.
- "Bit reversed" The code channels are displayed in the order defined by the Orthogonal Variable Spreading Factor (OVSF) code tree (3GPP code). The Walsh codes and their generation scheme are closely related to the spreading codes of 3GPP. Basically, the same spreading sequences are used, only the order in the respective code trees is different. According to 3GPP TS 25.213, the following code tree is used:

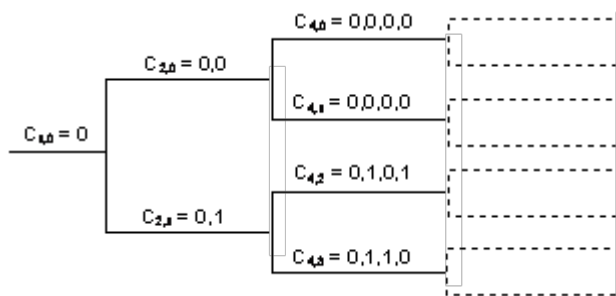

To find a 3GPP code that corresponds to a CDMA2000 code, the bit-inverted line (line index) has to be selected in the 3GPP matrix of identical spreading factor.

Example:

The 3GPP spreading code matching line 10 of the 16-bit Walsh code matrix is searched for. The binary form of the line index 10 (with 4 bits, because of Walsh length $16 = 2^4$) is 1010. The bit-inverted index is 0101, i.e. 5 in decimal notation. This means that the Walsh code No. 10 with the length 16 corresponds to the 3GPP spreading code 5 of the same length (spreading factor).

Remote command:

`[:SOURCE<hw>] :BB:C2K:BSTation<st>:DCONflict:MODE` on page 133

Channel Graph - Basestation

Opens the channel graph display to check the configured signal visually.

The channel graph display shows the active code channels. The channel number is plotted on the X axis. The red bars represent the special channels, the green bars the traffic channels. The channel index is plotted on the X-axis. The height of a bar shows the relative power of a channel.

The graph is calculated from the settings that have been made.

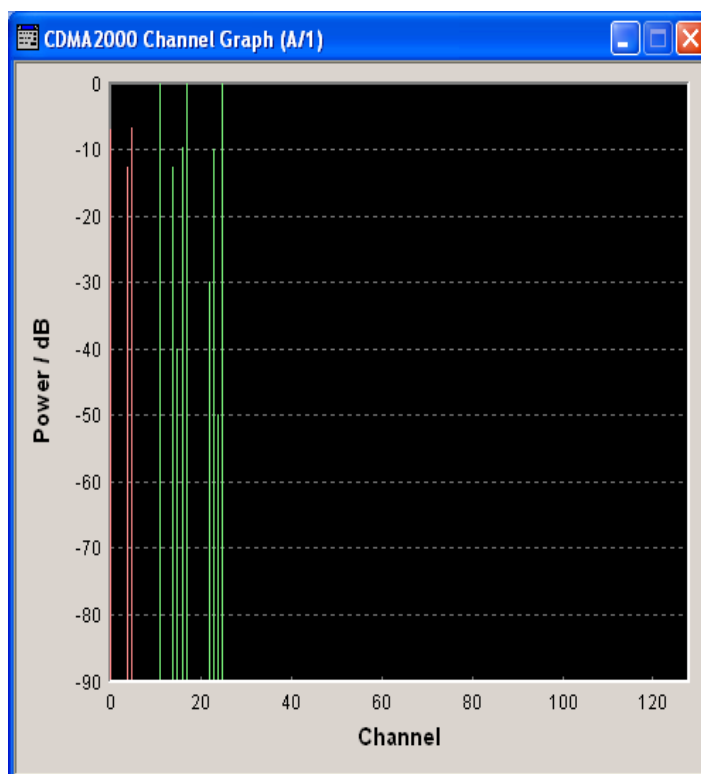

Remote command:
n.a.

4.7.3 Channel Table - BS

The "Channel table" is located in the lower part of the dialog. In the channel table, you can set the channel parameters individually.

Up to 78 channels are available for each base station. Channels 0 to 1 to 0 to 11 are assigned to the special channels which are responsible for the correct communication between base station and mobile station. The packet channels (0-12 to 0-14) and the traffic channels (1-0 and above) transmit the data.

A traffic channel is used for transmitting the radio link information, i.e. for communication with the addressee. The traffic channels consist of a dedicated channel, a fundamental channel and, depending on the radio configuration, of up to seven supplemental channels.

The packet data channel and the packet data control channels are used for transmitting data packets usually at higher data rates than is the case with purely circuit-mode traffic channels. The radio configuration of these channels is defined as 10 in accordance with the CDMA2000 standard.

The number of sub channels and the sub channel types of a traffic channel depend on the selected radio configuration. The radio configuration can be set separately for each traffic channel and is the same for all sub channels of this traffic channel. It determines among other things the channel coding types, the frame lengths and the data rates that

can be used and the settings of fixed parameter, e.g. CRC length. The R&S Signal Generator provides a separate set of settings of all channel table parameters for each radio configuration. Thus, when the radio configuration is changed, the current set of settings is internally stored for the old radio configuration. The complete set of settings belonging to the new radio configuration is activated and indicated in the channel table.

Channel 0-5 (F-SYNC) and the first traffic channel can be generated in real time.

R&S SMBV does not support realtime channels.

	Channel Type	Real Time	RC	Frame Length [ms]	Data Rate [kbps]	Walsh	Q. Orth.	Power [dB]	Data	Dist Pattern	More Params	State	Dom Conf
1	F-PICH			20.0	1.2	0	Off	0	PN 9		Config..	On	
2	F-TDPICH			20.0	1.2	0	Off	0	PN 9		Config..	On	
3	F-APICH			20.0	1.2	0	Off	0	PN 9		Config..	On	
4	F-ATDPICH			20.0	1.2	0	Off	0	PN 9		Config..	On	
5	F-SYNC	On		20.0	2.4	0	Off	0	PN 9		Config..	On	
6	F-PCH			20.0	9.6	0	Off	0	PN 9		Config..	On	
7	F-BCH			20.0	9.6	0	Off	0	All 1		Config..	On	
8	F-QPCH			20.0	1.2	0	Off	0	PN 9		Config..	On	
9	F-CPCH			20.0	1.2	0	Off	0	PN 9		Config..	On	
10	F-CACH			20.0	1.2	0	Off	0	PN 9		Config..	On	
11	F-CCCH			20.0	1.2	0	Off	0	PN 9		Config..	On	
12	F-PDCCH		10			0	Off	0	PN 9		Config..	Off	
13	F-PDCCH		10			0	Off	0	PN 9		Config..	On	

Channel Number

Displays the channel numbers.

The channel number is made up of two numbers. If the first number is 0 it identifies the special channels, i.e. the control channels and packet channels. A first number of 1 to 8 designates the traffic channels. The second number refers consecutively to the special channels or the subchannels of a traffic channel.

All available channels are always displayed, even the channels that are inactive. The number of subchannels per traffic channel 1 (four or eight) depends on the chosen radio configuration.

Each channel is switched on and off by the "On/Off" button in the "State" column.

Remote command:

In remote control, the channel is selected via the suffix to the keywords :CGRoup<n>:COFFset<n>.

CGRoup0 selects the special channels group, CGRoup1 to 8 the traffic channel.

COFFset1 to 14 selects either the special channel or the code channel of a traffic channel. E

For example, :CGRoup0:COFFset14 selects the packet channel F-PDCH, :CGRoup3:COFFset1 selects the F-FCH of traffic channel 3.

Channel Type

Indication of the channel type (see following table).

Table 4-2: List of supported channel types and their sequence in the CDMA2000 channel table

Index	Short form	Name	Function
0-1	F-PICH	Forward Pilot Channel	The base station continuously transmits the pilot channel. This channel provides capabilities for soft handoff and coherent detection. Handoff is a procedure where a mobile with an on-going call changes channel and/or base station under the supervision of the network. The Walsh code is 0.
0-2	F-TDPICH	Forward Transmit Diversity Pilot Channel	The base station continuously transmits this pilot channel from the secondary antenna when transmit diversity is enabled.
0-3	F-APICH	Forward Auxiliary Pilot Channel	This pilot channel transmits the base station as an option.
0-4	F-ATDPICH	Forward Auxiliary Transmit Diversity Pilot Channel	The base station optionally transmits this pilot channel from the secondary antenna when transmit diversity is enabled.
0-5	F-SYNC	Forward Synchronization Channel	The synchronization channel enables the mobile station to synchronize with the base station. It contains the PN offset, the system time and the long code status, information about the paging channel, together with the system ID and the network ID. The Walsh code is 32.
0-6	F-PCH	Forward Paging Channel	The paging channel carries control information specific to a mobile station when the network does not know where the mobile station is located.
0-7	F-BCCH	Forward Broadcast Channel	The broadcast channel is used to broadcast system- and cell-specific information.
0-8	F-QPCH	Forward Quick Paging Channel	The paging channel contains short form information for the mobile station, particularly if the latter is not transmitting.
0-9	F-CPCCH	Forward Common Power Control Channel	
0-10	F-CACH	Forward Common Assignment Channel	
0-11	F-CCCH	Forward Common Control Channel	General channel for transmitting control information. It also provides a mean for paging functions but it supports different data rates. It provides capability for short burst data communications.
0-12/13	F-PDCCH	Forward Packet Data Control Channel	The F-PDCCH carries the control information for the F-PDCH.
0-14	F-PDCH	Forward Packet Data Channel	Packet-oriented data channel, supports high data rates
1-1	F-FCH	Forward Fundamental Channel	Subchannel of a traffic channel. Contains control data and user data.
1-2	F-SCCH1	Forward Supplemental Code Channel	Subchannel of a traffic channel. Enables higher data rates for control and user data.

Index	Short form	Name	Function
1-2	F-SCH1	Forward Supplemental Channel	Subchannel of a traffic channel. Enables higher data rates for control and user data.
...			
1-4	F-DCCH	Forward Dedicated Control Channel (RC3, RC4 and RC5)	Subchannel of a traffic channel. It transports specific control information.

Remote command:

```
[ :SOURCE<hw> ] :BB:C2K:BSTation<st>:CGROUP<di0>:COFFset<ch>:TYPE?
```

on page 132

Real Time - BS1

(not available in R&S SMBV)

Activates realtime generation of the channel. This option is only available for the sync channel F-SYNC and the first traffic channel. The set state for the first traffic channel is specific for the selected radio configuration.

Tip: Feed through artificial bit errors and block errors to the CRC checksum to all the data sources to test the BER/BLER testers that are integrated in the BS.

Remote command:

```
[ :SOURCE<hw> ] :BB:C2K:BSTation<st>:CGROUP<di0>:COFFset<ch>:
```

REALtime:STATE on page 127

Radio Configuration (RC)

Selects radio configuration of the traffic channel.

The radio configuration determines the channel types, the frame lengths, the channel coding types and the data rates that can be used.

The radio configuration is the same for all sub channels of a traffic channel. If the radio configuration is modified for one of the sub channels, the new value is then automatically used by all other subchannels of this traffic channel.

The radio configuration for the packet channels F-PDCCH and F-PDCH is fixed to RC10.

The R&S Signal Generator provides a separate set of settings of all channel table parameters for each radio configuration. Changing the radio configuration causes the settings belonging to the new RC value to be activated in the channel table (the settings belonging to the old RC value are stored).

The radio configuration determines the permissible frame lengths. The frame length defines the permitted data rate and channel coding type which in turn determine the permitted Walsh codes.

This causes a hierarchy within the following parameters:

"Frame Length" -> "Data Rate + Channel Coding Type" -> "Walsh Code"

Changing one of the parameters in this hierarchy automatically causes the lower-level settings to be changed if they are no longer permitted following the change to the higher-level parameter.

Remote command:

[:SOURce<hw>] :BB:C2K:BSTation<st>:CGRoup<di0>:RCONfiguration
on page 133

Frame Length- BS

Enters the frame length of the channel. The set value is specific for the selected radio configuration.

The value range depends on the channel type and radio configuration. The frame length of the F-SCH is fixed to 26.6.ms. The maximum frame length is 160 ms, the minimum frame length is 5 ms.

The frame length affects the data rates and the channel coding types that are possible within a channel. Changing the frame length can lead to a change of data rate and/or the channel coding type and this in turn can bring about a change of the Walsh code.

Remote command:

[:SOURce<hw>] :BB:C2K:BSTation<st>:CGRoup<di0>:COFFset<ch>:
FLENgth on page 125

Data Rate

Enters the data rate of the channel. The set value is specific for the selected radio configuration.

The R&S Signal Generator supports all data rates between 1.2 kbps and 1,036.8 kbps defined in the standard.

The value range depends on the frame length. If the frame length is changed so that the set data rate becomes invalid, the next permissible value is automatically set.

The data rate affects the Walsh code (spreading factor) that is possible within a channel. If a data rate is changed so that the selected Walsh code becomes invalid, the next permissible value is automatically set.

Remote command:

[:SOURce<hw>] :BB:C2K:BSTation<st>:CGRoup<di0>:COFFset<ch>:DATA:
RATE on page 123

Walsh Code

Assigns the Walsh code to the channel (see [Chapter 3.7, "Variable-Length Walsh Spreading - Downlink"](#), on page 15, and see ["Code Domain Graph - BS"](#) on page 51). The set value is specific for the selected radio configuration.

The code channel is spread with the set Walsh code (spreading code).

The value range of the Walsh code depends on the frame length, the channel coding type and the data rate.

If one of these parameters is changed so that the set Walsh code gets invalid, the next permissible value is automatically set.

The standard assigns a fixed Walsh code to some channels (F-PICH, for example, always uses Walsh code 0). Generally, the Walsh code can only be varied within the range specified by the standard.

Remote command:

[:SOURce<hw>] :BB:C2K:BSTation<st>:CGRoup<di0>:COFFset<ch>:WCODE
on page 132

Quasi Orthogonal Walsh Code State

Activates/deactivates the use of the quasi-orthogonal Walsh codes for the channel. The set state is specific for the selected radio configuration.

Depending on the channel type and other parameters, the standard does not allow the use of quasi-orthogonal codes. In this case, the selection field is dimmed.

The quasi-orthogonal Walsh code set is selected for all channels of the base station in the upper area of the CDMA200 dialog.

Remote command:

```
[ :SOURce<hw> ] :BB:C2K:BSTation<st>:CGROUP<di0>:COFFset<ch>:
QWCode:STATE on page 127
```

Power

Sets the channel power in dB. The set value is specific for the selected radio configuration.

The power entered is relative to the powers outputs of the other channels. If "Adjust Total Power to 0 dB" is executed (top level of the CDMA dialog), all the power data is relative to 0 dB.

The set "Power" value is also the start power of the channel for "Misuse For Output Power Control".

Note: The maximum channel power of 0 dB applies to non-blanked channels (duty cycle 100%).

With blanked channels, the maximum value can be increased to values greater than 0 dB. Where the maximum value is calculated as:

$$10 * \log_{10} 1 / \text{duty_cycle}$$

Remote command:

```
[ :SOURce<hw> ] :BB:C2K:BSTation<st>:CGROUP<di0>:COFFset<ch>:POWER
on page 126
```

Data

Selects data source. The set value is specific for the selected radio configuration.

The following standard data sources are available:

- "All 0, All 1"
An internally generated sequence containing 0 data or 1 data.
- "PNxx"
An internally generated pseudo-random noise sequence.
- "Pattern"
An internally generated sequence according to a bit pattern.
Use the "Pattern" box to define the bit pattern.
- "Data List/Select DList"
A binary data from a data list, internally or externally generated.
Select "Select DList" to access the standard "Select List" dialog.
 - Select the "Select Data List > navigate to the list file *.dm_iqd > Select" to select an existing data list.
 - Use the "New" and "Edit" functions to create internally new data list or to edit an existing one.
 - Use the standard "File Manager" function to transfer external data lists to the instrument.

See also "Main Dialog > Data List Management".

Remote command:

`[:SOURCE<hw>] :BB:C2K:BSTation<st>:CGROUP<di0>:COFFset<ch>:DATA`
on page 121

`[:SOURCE<hw>] :BB:C2K:BSTation<st>:CGROUP<di0>:COFFset<ch>:DATA:`
`PATtern` on page 123

`[:SOURCE<hw>] :BB:C2K:BSTation<st>:CGROUP<di0>:COFFset<ch>:DATA:`
`DSElect` on page 122

More Params

Provides access to a dialog covering additional parameters of the selected channel (see [Chapter 4.8, "More Parameters - BS Channel Table"](#), on page 61).

Remote command:

n.a.

Channel State

Activates or deactivates the channel. The set state is specific for the selected radio configuration.

Remote command:

`[:SOURCE<hw>] :BB:C2K:BSTation<st>:CGROUP<di0>:COFFset<ch>:STATE`
on page 127

Domain Conflict

Displays whether the channel has a code domain conflict with another channel. If there is a conflict, a red dot appears and the column is colored soft orange. If there is no conflict, the column is colored soft blue. The indicated value is specific for the selected radio configuration.

To access the graphical display of code domain occupancy by all the active code channels, use the "Code Domain" button (also see ["Code Domain Graph - BS"](#) on page 51).

Remote command:

`[:SOURCE<hw>] :BB:C2K:BSTation<st>:DCONflict[:STATE]?` on page 134

`[:SOURCE<hw>] :BB:C2K:BSTation<st>:DCONflict:RESolve` on page 134

4.8 More Parameters - BS Channel Table

The "More Parameters" dialog can be called in the BS channel table in column "More Params" with button "Config...". The indicated values and the settings are specific for the selected radio configuration.

The settings for the packet channel F-PDCH channel and all other channels are different (see [Chapter 4.9, "More Parameters for F-PDCH - BS"](#), on page 71). The dialog for the special channels and the traffic channels is described below.

The upper section is where the channel number, channel type and Walsh length of the selected channel is displayed.

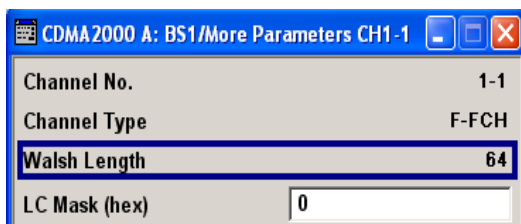

The "Power Control" section is where the settings for the power control bits are made. This section is only available for the traffic sub channels F-FCH and F-DCCH.

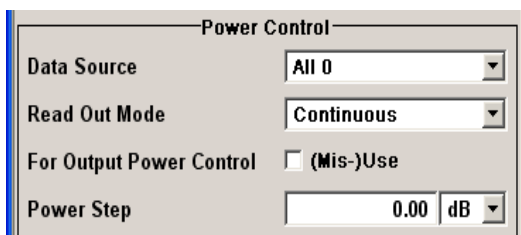

The "Channel Coding" section is where the channel coding settings are made.

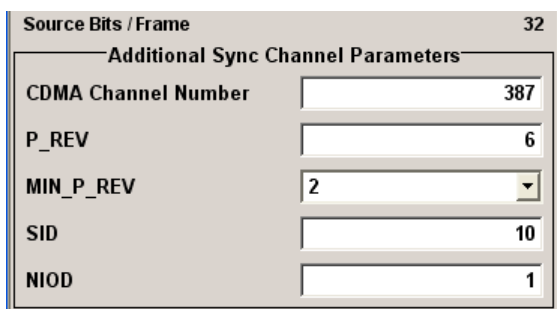
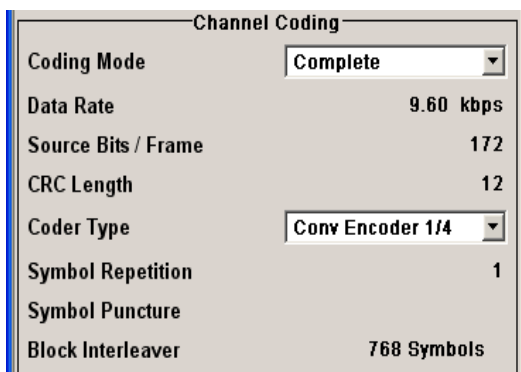

The "Bit/Block Error Insertion" section is where the bit/block error simulation is configured and activated.

This section is only available for the realtime channels.

Bit Error Insertion	
State	<input type="checkbox"/>
Bit Error Rate	<input type="text" value="0.001 000 0"/>
Block Error Insertion	
State	<input type="checkbox"/>
Block Error Rate	<input type="text" value="0.100 0"/>

4.8.1 General Settings

In the upper section, the channel number, channel type and Walsh length of the selected channel are displayed.

Channel No - More Parameters BS

Displays the channel number of the channel.

Remote command:

n.a.

Channel Type - More Parameters BS

Displays the type of the channel.

Remote command:

n.a.

Walsh Length - More Parameters BS

Displays the Walsh code of the channel. The indicated value is specific for the selected radio configuration.

Remote command:

`[:SOURCE<hw>] :BB:C2K:BSTation<st>:CGROUP<di0>:COFFset<ch>:WLENgth?` on page 133

LC Mask (hex) - More Parameters BS

Enters the mask of the long-code generator in hexadecimal form. The set value is specific for the selected radio configuration.

The long-code mask is a 42-bit value. The mask serves for channel-specific and user-specific scrambling of the code channel.

The LC Mask is the same for all sub channels of a traffic channel. If the mask is modified for one of the sub channels, the new value is then automatically used by all other subchannels of this traffic channel.

Remote command:

`[:SOURCE<hw>] :BB:C2K:BSTation<st>:CGROUP<di0>:COFFset<ch>:LCMask` on page 126

4.8.2 Power Control

In this section, you can configure the settings for the power control bits. These bits are used to control the transmission power.

This section is only available for the traffic sub channels F-FCH and F-DCCH.

Data Source - Power Control - BS

Defines the data source for the power control bits of the channel. The set value is specific for the selected radio configuration.

The following standard data sources are available:

- "All 0, All 1"
An internally generated sequence containing 0 data or 1 data.
- "PNxx"
An internally generated pseudo-random noise sequence.
- "Pattern"
An internally generated sequence according to a bit pattern.
Use the "Pattern" box to define the bit pattern.
- "Data List/Select DList"
A binary data from a data list, internally or externally generated.
Select "Select DList" to access the standard "Select List" dialog.
 - Select the "Select Data List > navigate to the list file *.dm_iqd > Select" to select an existing data list.
 - Use the "New" and "Edit" functions to create internally new data list or to edit an existing one.
 - Use the standard "File Manager" function to transfer external data lists to the instrument.

See also "Main Dialog > Data List Management".

Remote command:

`[:SOURce<hw>] :BB:C2K:BSTation<st>:CGRoup<di0>:COFFset<ch>:TPC:DATA` on page 128

`[:SOURce<hw>] :BB:C2K:BSTation<st>:CGRoup<di0>:COFFset<ch>:TPC:DATA:PATtern` on page 129

`[:SOURce<hw>] :BB:C2K:BSTation<st>:CGRoup<di0>:COFFset<ch>:TPC:DATA:DSElect` on page 128

Read Out Mode (Power Control) - BS

Defines power control bits usage. The set value is specific for the selected radio configuration.

With CDMA, the power control bits are used to signal the increase or reduction in transmit power to the called station.

The BS sends power control bits in the traffic channel at an 800 Hz rate instead of the scrambled data bits. The mobile station increases or decrease its output power depending on these power control bits. One to four data bits (depending on the data rate) are replaced a corresponding number of power control bits ("0...0" or "1...1").

With all read out modes, 1 bit is taken from the power control, multiplied and entered into the bitstream. The difference between the modes lies in the usage of the power control bits.

These different modes can be used to set a BS to a specific output power (e.g. with the pattern 11111) and then let it oscillate around this power. This then allows power measurements to be carried out at the BS (at quasi-constant power).

Together with the option misuse output power control (see [Misuse for Output Power Control - BS](#)), this parameter can also be used to generate various output power profiles.

"Continuous"	The power control bits are used cyclically.
"Single + All 0"	The power control bits are used once, and then the power control sequence is continued with 0 bits.
"Single + All 1"	The power control bits are used once, and then the power control sequence is continued with 1 bit.
"Single + alt. 01"	The power control bits are used once. The power control sequence is continued with 0 bits and 1 bit alternately (in multiples, depending on the data rate, for example, 00001111).
"Single + alt. 10"	The power control bits are used once. The power control bit sequence is continued with 1 bit and 0 bits alternately (in multiples, depending on the data rate, for example, 11110000).

Remote command:

`[:SOURCE<hw>] :BB:C2K:BSTation<st>:CGRoup<di0>:COFFset<ch>:TPC:READ` on page 131

Misuse for Output Power Control - BS

Activates "(Mis-) Use " of the power control data. The set value is specific for the selected radio configuration.

The power control bits are used to signal the increase or reduction of transmit power to the called station.

If "(Mis-) Use for Output Power Control" is activated, the specified pattern is used to vary the intrinsic transmit power over time. Every 1.25 ms (800 Hz) a bit of this pattern is removed in order to increase (bit = "1") or reduce (bit = "0") the channel power by the specified "Power Step". The upper limit is 0 dB and the lower limit -80 dB.

The following envelope is produced with the settings:

- Channel power = 0 dB
- Power step = 1.0 dB
- Pattern = "001110100000011"
- "TPC Read Out Mode = Continuous"

Note: The first bit is assigned to the first power control section. In this first section, the start power specified in the channel table is always used. Only in the next power control section (with the second power control bit) will the defined power change be effective.

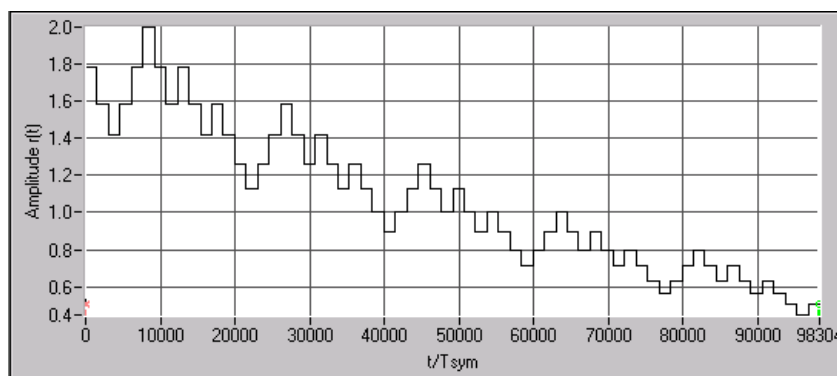

Figure 4-5: Dynamic change of channel power (continuous)

Remote command:

`[:SOURCE<hw>] :BB:C2K:BSTation<st>:CGROUP<di0>:COFFset<ch>:TPC: MISuse` on page 130

Power Step (DPCCH) - BS

Sets the step width of the power change in dB for "(Mis-) use TPC for output power control".

The set value is specific for the selected radio configuration.

Remote command:

`[:SOURCE<hw>] :BB:C2K:BSTation<st>:CGROUP<di0>:COFFset<ch>:TPC: PSTep` on page 130

4.8.3 Channel Coding

In this section, you can configure the settings for the channel coding. The indicated values and the settings are specific for the selected radio configuration.

In contrast to 3GPP FDD, channel coding with CDMA2000 is part of the physical layer. The channel coding procedure can slightly vary depending on channel type, frame length and data rate.

Channel Coding Mode - More Params BS

Activates or deactivates channel coding. The set state is specific for the selected radio configuration.

"Off"

Channel coding is deactivated.

Channel coding is not performed. The data sources of the individual channels apply their data stream directly to the long-code scrambler. The data source supplies the traffic data with the data rate that would be available at the long-code scrambler after coding is switched on. This effective data rate, which is used for reading off from the data source, is indicated with the parameter "Effective Data Rate". The `Data Rate` parameter displayed in the channel table continues to affect the "Effective Data Rate", but no longer agrees with it.

"Complete"	The complete channel coding is performed. The channel coding procedure can slightly vary depending on channel type, frame length and data rate.
"Without Interleaving"	Except for the block interleaver, the whole channel coding procedure is carried out. In this mode, the frame structure and the convolutional coder of a receiver can be tested.
"Interleaving Only"	In this mode, only a block interleaver is used for coding. This allows the deinterleaver in the receiver to be tested independently of the remaining (de-)coding process.

Remote command:

[:SOURCE<hw>] :BB:C2K:BSTation<st>:CGROUP<di0>:COFFset<ch>:
CCODing:MODE on page 119

Effective Data Rate - More Params BS

Indicates the effective data rate. The value is specific for the selected radio configuration.

For coding modes "Interleaving Only" and "Coding Off", the effective data rate differs from the set data rate. This is because no increase in the data rate is brought about by the convolution coder. The data rate set in the channel table is therefore not correct.

For coding modes "Without Interleaving" and "Complete", the data rate in the channel table agrees with the effective data rate. This is because there is an increase in the data rate due to the convolution coder.

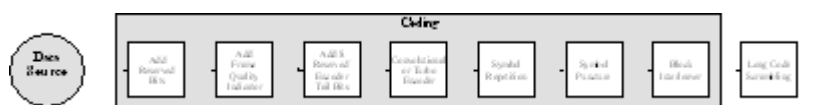

Remote command:

[:SOURCE<hw>] :BB:C2K:BSTation<st>:CGROUP<di0>:COFFset<ch>:
CCODing:DATA:RATE? on page 119

Source Bits / Frame - More Params BS

Indicates the number of input bits per frame for the channel coder. The indicated value is specific for the selected radio configuration.

Remote command:

[:SOURCE<hw>] :BB:C2K:BSTation<st>:CGROUP<di0>:COFFset<ch>:
CCODing:BITFrame? on page 118

CRC Length - More Params BS

Indicates the CRC (cyclic redundancy code) type (length) for error identification. The indicated value is specific for the selected radio configuration.

Remote command:

n.a.

Channel Coder Type - More Params BS

Selects error protection. The set value is specific for the selected radio configuration.

Which coder types are available depends on the channel type and other channel settings such as frame length.

If one of these parameters is changed so that the set channel coding type gets invalid, the next permissible value is automatically set.

"Off"	No error protection. This selection is available for the pilot channels only.
"Conv Encoder"	Convolution coder with generator polynomials defined by CDMA. The numeric value defines the rate of the convolution coder.
"Turbo Encoder"	Turbo coder of rate 1/3 in accordance with the CDMA specifications. The numeric value defines the rate of the turbo coder.

Remote command:

`[:SOURce<hw>] :BB:C2K:BSTation<st>:CGRoup<di0>:COFFset<ch>:CCODing:TYPE` on page 121

Symbol Repetition - More Params BS

Indicates the symbol repetition rate. The value is specific for the selected radio configuration.

Symbol repetition is used together with block symbol puncture for adapting the convolutional or turbo coder output data rate to the required input data rate of the interleaver.

Remote command:

`[:SOURce<hw>] :BB:C2K:BSTation<st>:CGRoup<di0>:COFFset<ch>:CCODing:SREPetition?` on page 120

Symbol Puncture - More Params BS

Indicates the symbol puncture rate. The value is specific for the selected radio configuration.

Symbol puncturing (elimination) is used together with block symbol repetition for adapting the convolutional or turbo coder output data rate to the required input data rate of the interleaver.

Remote command:

`[:SOURce<hw>] :BB:C2K:BSTation<st>:CGRoup<di0>:COFFset<ch>:CCODing:SPUNcture?` on page 120

Block Interleaver - More Params BS

Displays the number of symbols that the interleaver processes per block. The indicated value is specific for the selected radio configuration.

Remote command:

`[:SOURce<hw>] :BB:C2K:BSTation<st>:CGRoup<di0>:COFFset<ch>:CCODing:BINTerleaver?` on page 117

4.8.4 Additional Sync Channel Parameters

1. To access this dialog, select "CDMA 2000 > General > Link Direction > Downlink / Forward".
2. Select "Base Stations > Select Base Station > BS1...BS4".

3. Select "Channel Table > F-SYNC > More Params > Config".

Source Bits / Frame	32
Additional Sync Channel Parameters	
CDMA Channel Number	387
System Time	0
LC State (hex)	0000 0000 000
P_REV	6
MIN_P_REV	2
SID	10
NID	1

This section contains the additional parameters for the channel type F-SYNC.

CDMA Channel Number - More Params BS

Displays the CDMA channel number which corresponds to the RF.

Remote command:

[\[:SOURCE<hw>\]:BB:C2K:BSTation:SYNC:CNUMBER](#) on page 115

System Time - More Params BS

(available for R&S SMBV only)

Displays the system time.

Remote command:

[\[:SOURCE<hw>\]:BB:C2K:BSTation:SYNC:STIME](#) on page 117

LC State (hex) - More Params BS

(available for R&S SMBV only)

Defines the long code state in hexadecimal format.

Remote command:

[\[:SOURCE<hw>\]:BB:C2K:BSTation:SYNC:LCSTATE](#) on page 115

P_REV - More Params BS

Displays the Protocol revision level that specifies the CDMA2000 system release number.

The table below gives the cross-reference between the P_REV values and the CDMA2000 releases.

P_REV	CDMA2000 release
1	Korean PCS(Band Class4), USPCS(Band Class1)
2	IS-95
3	TBS74
4	IS-95A
5	IS-95B
6	IS2000 Release 0

P_REV	CDMA2000 release
7	IS2000 Release A
8	IS2000 Release B

Remote command:

`[:SOURCE<hw>] :BB:C2K:BSTation:SYNC:PREV` on page 116

MIN_P_REV - More Params BS

Displays the minimum protocol revision level.

The BS sets this field to prevent mobile stations which cannot be supported by the BS from accessing the CDMA system.

Remote command:

`[:SOURCE<hw>] :BB:C2K:BSTation:SYNC:MPRev` on page 115

SID - More Params BS

Displays the system identification.

The BS sets the system identification number.

Remote command:

`[:SOURCE<hw>] :BB:C2K:BSTation:SYNC:SID` on page 116

NID - More Params BS

Displays the network identification.

The NID serves as a subidentifier of a CDMA system as defined by the owner of the SID.

Remote command:

`[:SOURCE<hw>] :BB:C2K:BSTation:SYNC:NID` on page 116

4.8.5 Error Insertion

(not available in R&S SMBV)

In the "Bit/Block Error Insertion" sections, errors can be inserted into the data source and into the CRC checksum. This can be used to check the bit and block error rate testers.

These functions are available for realtime channels only.

Bit Error Insertion	
State	<input type="checkbox"/>
Bit Error Rate	<input type="text" value="0.001 000 0"/>
Block Error Insertion	
State	<input type="checkbox"/>
Block Error Rate	<input type="text" value="0.100 0"/>

Bit Error State - More Params BS

Activates or deactivates bit error generation.

Bit errors are inserted into the data fields of the realtime channels.

When the data source is read out, bits are deliberately inverted at random points in the data bitstream with the specified error rate so that invalid signal is simulated.

Remote command:

```
[ :SOURce<hw> ] :BB:C2K:BSTation<st>:CGROUP<di0>:COFFset<ch>:
DError:BIT:STATE on page 124
```

Bit Error Rate - More Params BS

Sets the bit error rate.

Remote command:

```
[ :SOURce<hw> ] :BB:C2K:BSTation<st>:CGROUP<di0>:COFFset<ch>:
DError:BIT:RATE on page 124
```

Block Error State - More Params BS

Activates or deactivates the block error generation.

The CRC checksum is determined and then the last bit is inverted at the specified error probability in order to simulate an invalid signal.

Block error generation is only possible with channel coding enabled.

Remote command:

```
[ :SOURce<hw> ] :BB:C2K:BSTation<st>:CGROUP<di0>:COFFset<ch>:
DError:BLOCK:STATE on page 125
```

Block Error Rate - More Params BS

Sets the block error rate.

Remote command:

```
[ :SOURce<hw> ] :BB:C2K:BSTation<st>:CGROUP<di0>:COFFset<ch>:
DError:BLOCK:RATE on page 124
```

4.9 More Parameters for F-PDCH - BS

The "More Parameters" dialog for packet channel F-PDCH can be called in the BS channel table in column "More Params" with button "Config...".

The settings for the packet channel F-PDCH channel and all other channels are different (see [Chapter 4.8, "More Parameters - BS Channel Table"](#), on page 61). The dialog for the special channels and the traffic channels is described below.

The channel coding for the F-PDCHs is always carried out in full (see 3GPP2 C.S0002-C figure 3.1.3.1.1.1-19).

The parameters of both F-PDCHs (such as Number of Slots per Subpacket, Subpacket Position) are implicitly defined by the F-PDCH settings, since both these channels are always transmitted simultaneously with the F-PDCH. The "More Parameters"

dialog for these F-PDCCCHs is therefore mostly for display, it only enables you to select the channel coding mode.

The left part is used to enter the general settings for the packet channel.

The right, upper part contains a table for setting the parameters of the subpackets. Up to eight subpackets can be transmitted for each regular packet.

The right, lower part displays the current configuration of the packet channel in graphical form.

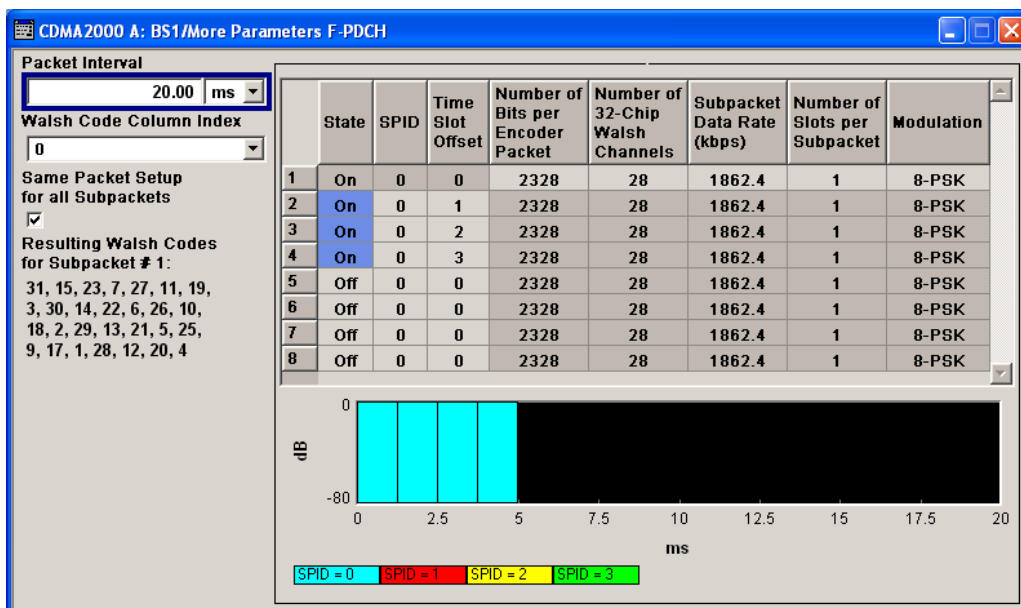

4.9.1 General Settings for Packet Channel

In the left section, you can configure the general settings for the packet channel.

Packet Interval - More Params F-PDCHs BS

Selects the interval at which new data packets arrive.

New F-PDCH packets are generated in this interval. Within an interval, up to eight subpackets of a data packet can be transmitted with any required time offset.

The value range is dependent on the set sequence length (ARB settings). The values 80 ms, 40 ms, 20 ms, 10 ms and 5 ms can always be set, and the maximum value is 2000 ms. All intermediate values must satisfy the condition

$$\text{Sequence Length} = * 80\text{ms}/2^n$$

where n is a whole number.

Example:

Sequence length = one 80 ms frame.

The possible values for the packet interval are 80 ms, 40 ms, 20 ms, 10 ms and 5 ms.

Sequence length = three 80 ms frames.

The possible values for the packet interval are 240 ms, 120 ms, 80 ms, 40 ms, 20 ms, 10 ms and 5 ms.

Remote command:

[\[:SOURCE<hw>\]:BB:C2K:BSTation<st>:PDCHannel:PINTERval](#) on page 134

Walsh Code Column Index - More Params F-PDCHs BS

Selects the standard-compliant set of available Walsh codes for the F_PDCH (see 3GPP2 C.S0003-C, table 2-35).

Remote command:

[\[:SOURCE<hw>\]:BB:C2K:BSTation<st>:PDCHannel:WINDEX](#) on page 141

Same Packet Setup... - More Params F-PDCHs BS

Activates that all subpackets are generated with the same settings.

If enabled, you can only set the parameters of subpackage1 (number of bits, etc., see [Subpacket Table Settings](#)). The same settings are automatically assigned to all subpackets.

The "Off" setting allows individual settings for each subpacket.

Remote command:

[\[:SOURCE<hw>\]:BB:C2K:BSTation<st>:PDCHannel:PSETup](#) on page 135

4.9.2 Subpacket Table Settings

The middle part contains a table for setting the parameters of the subpackets. Up to eight subpackets can be transmitted for each regular packet (Encoder Packet).

	State	SPID	Time Slot Offset	Number of Bits per Encoder Packet	Number of 32-Chip Walsh Channels	Subpacket Data Rate (kbps)	Number of Slots per Subpacket	Modulation
1	On	0	0	2328	28	1862.4	1	8-PSK
2	On	0	1	2328	28	1862.4	1	8-PSK
3	On	0	2	2328	28	1862.4	1	8-PSK
4	On	0	3	2328	28	1862.4	1	8-PSK
5	Off	0	0	2328	28	1862.4	1	8-PSK
6	Off	0	0	2328	28	1862.4	1	8-PSK
7	Off	0	0	2328	28	1862.4	1	8-PSK
8	Off	0	0	2328	28	1862.4	1	8-PSK

Subpacket Number - More Params F-PDCHs BS

Denotes the index number of the subpackets in the selected channel. Each packet can include up to eight subpackets.

The subpacket is selected by the suffix to `SUBPacket` in remote control.

Subpacket State - More Params F-PDCHs BS

Activates a subpacket.

Subpacket 1 is always active. The rest can be turned on and off.

Remote command:

```
[ :SOURCE<hw> ] :BB:C2K:BSTation<st>:PDCHannel:SUBPacket<di>:STATE
on page 140
```

Subpacket ID (SPID) - More Params F-PDCHs BS

Selects the subpacket ID.

The subpacket ID controls the subpacket symbol selection and adopts one of four possible subpackets from the encoder packet.

The ID of the first subpacket is fixed at 0. The ID can be chosen for each of the rest.

Remote command:

```
[ :SOURCE<hw> ] :BB:C2K:BSTation<st>:PDCHannel:SUBPacket<di>:ID
on page 135
```

Time Slot Offset - More Params F-PDCHs BS

Sets the starting time of the subpacket relative to the starting time of the packet interval.

The first subpacket always has an offset of 0, which cannot be changed.

The value range for the individual subpackets depends on the settings of the other subpackets:

The time slot offsets of the remaining subpackets must be entered in ascending order. Also it is not permitted to transmit two packets simultaneously.

Example:

Subpacket 2 is transmitted in time slot 5 and is four slots long. Subpacket 3 can only be transmitted in time slot 9 and no sooner.

In total, the value range is 0 to (Packet Interval/1.25 ms -Number of Slots per Subpacket).

Example:

Packet Interval = 20 ms, Number of Slots per Subpacket = 2. The value range is 0 to 14.

The entry for "Number of Slots per Subpacket" defines the length of a packet.

Remote command:

```
[ :SOURCE<hw> ] :BB:C2K:BSTation<st>:PDCHannel:SUBPacket<di>:
TOFFset on page 141
```

PDCH Subpacket Table Parameters - More Params F-PDCHs BS

Only certain combinations of this parameter with the parameters of the last five table columns are possible. These combinations are shown in the selection list in the form of a table for all five parameters.

Number of Bits per Encoder Packet	Number of 32-Chip Walsh Channels	Subpacket Data Rate (kbps)	Number of Slots per Subpacket	Modulation
2328	28	1862.4	1	8-PSK
2328	28	1862.4	1	8-PSK
3864	27	1545.6	2	QPSK
3096	26	2476.8	1	16-QAM
3864	26	3091.2	1	16-QAM
1560	25	1248.0	1	QPSK
2328	25	1862.4	1	8-PSK
3096	25	1238.4	2	QPSK
3864	25	1545.6	2	8-PSK
2328	23	931.2	2	QPSK
2328	23	1862.4	1	16-QAM

"Number of Bits per Encoder Packet"

Sets the number of bits per encoder packet.

The "Number of Bits per Encoder Packet" defines the number of data bits that can be read from the data source for an encoder packet. Due to the channel coding, this number is multiplied by a factor of about 5. The subsequent subpacket symbol selection then divides these bits into four different subpackets which can be selected via the SPID parameter.

The "Number of Bits per Encoder Packet" can only be changed for subpacket 1. This value must be identical for the remaining subpackets, since they are all part of a single encoder packet.

"Number of 32-Chip Walsh Channels"

Selects the number of 32-chip Walsh channels.

"Subpacket Data Rate (kbps)"

Selects the data rate of the subpacket.

The data rate is the result of the "Number of Bits per Encoder Packet" divided by the duration of the subpacket (= "Number of Slots per Subpacket"). Therefore only specified combinations of the "Subpacket Data Rate" with the "Number of Slots per Subpacket" at a specified "Number of Bits per Encoder Packet" are possible.

"Number of Slots per Subpacket"

Selects the number of slots per subpacket. This parameter defines the duration of the subpacket. A slot equals 1.25 ms.

The "Number of Slots per Subpacket" is the result of the "Number of Bits per Encoder Packet" divided by the data rate. Therefore only specified combinations of the Subpacket Data Rate with the "Number of Slots per Subpacket" at a specified "Number of Bits per Encoder Packet" are possible.

"Modulation"

Indication of the modulation type.

The modulation type is fix for each combination of the above parameters.

Remote command:

```
[ :SOURce<hw> ] :BB:C2K:BSTation<st>:PDChannel:SUBPacket<di>:
PARAMeters on page 136
```

Resulting Walsh Codes for Subpacket - More Params F-PDCHs BS

Indicates the resulting Walsh codes for the sub packet.

Remote command:

```
[ :SOURce<hw> ] :BB:C2K:BSTation<st>:PDCHannel:SUBPacket<di>:
WCODeS? on page 141
```

4.9.3 Subpacket Graph

Displays the current configuration of the packet channel and its active subpackets graphically.

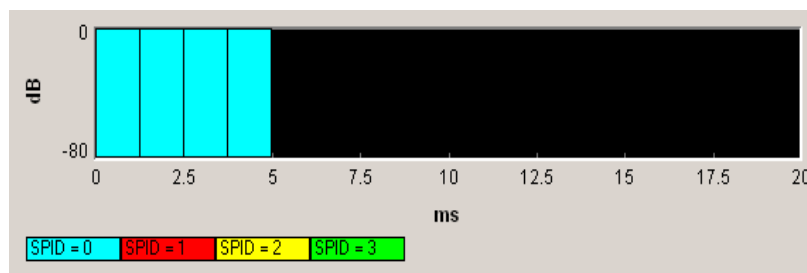

The X axis is the length of the set packet interval in ms, i.e. the duration of the transmission of an encoder packet.

The relative power of the subpackets is represented on the Y axis. The subpackets are shown as bars and are one, two or four time slots wide according to the configuration. The position on the X axis corresponds to the selected time slot offset.

The color of the bar depends on the sub packet ID (SPID). The assignment of colors to SPIDs is shown below the graph.

4.10 Mobile Station Configuration (MS)

The "Mobile Station Configuration" dialog is called by selecting mobile station "MS1 ... MS4" in the CDMA2000 dialog.

The dialog is divided into the sections "Common Settings", "Power Control" and "Channel Table".

The structure of the channel table depends on the selected operating mode and - for the traffic channel - on the selected radio configuration.

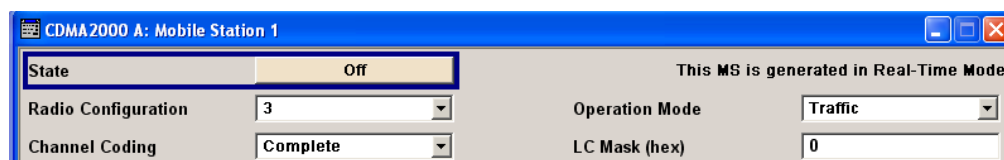

Power Control										
Data Source	All 0									
Read Out Mode	Continuous									
Power Step	0.00 dB									
										For Output Power Control <input type="checkbox"/> (Mis-)Use

	Channel Type	Frame Length [ms]	Data Rate [kbps]	Walsh	Spread	Power [dB]	Data	Dlist Pattern	State
1	R-PICH	20.0	NotUsd	0	32	0.00	PN 9		Off
2	R-DCCH	20.0	9.6	8	16	0.00	PN 9		Off
3	R-FCH	20.0	1.5	4	16	0.00	PN 9		Off
4	R-SCH1	20.0	1.5	2	16	0.00	PN 9		Off
5	R-SCH2	20.0	1.5	6	16	0.00	PN 9		Off

4.10.1 Common Settings - MS

The "Common Settings" section is where the general settings for the selected mobile station are made.

State - MS

Activates or deactivates the selected mobile station. The number of the selected mobile station is specified in the dialog header.

Remote command:

[\[:SOURce<hw>\]:BB:C2K:MSTation<st>:STATE](#) on page 154

Operation Mode - MS

Selects the mode in which the mobile station is to work.

The operation mode defines the generated channel types. The lower part of the dialog changes in accordance with the mode. The following modes are available:

- | | |
|-------------------|--|
| "Traffic" | In this mode, the instrument generates a single traffic channel. A traffic channel consists of up to eight sub channels depending on the selected radio configuration.
This mode corresponds to the standard mode of a mobile station during voice and data transmission. |
| "Access" | In this mode, the instrument generates an access channel (R-ACH). This channel is needed to set up the connection between the mobile station and the base station. |
| "Enhanced Access" | In this mode, the instrument generates an enhanced access channel (R-ACH) and a pilot channel (R-PICH). These channels are used to set up the connection between the mobile station and the BS. |
| "Common Control" | In this mode, the instrument generates a common control channel (R-ACH) and a pilot channel (R-PICH). |

Remote command:

[\[:SOURce<hw>\]:BB:C2K:MSTation<st>:MODE](#) on page 152

Radio Configuration - MS

Selects the radio configuration for the traffic channel.

In the reverse link, the channel scenario with the spreading codes of the individual channels is predefined by selecting the radio configuration. For this reason, the channel table does not contain selection parameters for the Walsh code.

A separate set of settings of all channel table parameters is provided for each radio configuration. Changing the radio configuration causes the settings belonging to the new RC value to be activated in the channel table. The settings belonging to the old RC value are not lost.

The radio configuration determines the permissible frame lengths and the frame length defines the permitted data rate.

Changing the frame length automatically causes the data rate to be changed if it is no longer permitted.

Remote command:

[\[:SOURCE<hw>\]:BB:C2K:MSTation<st>:RCONfiguration](#) on page 153

Channel Coding - MS

Activates or deactivates channel coding.

"Off"	Channel coding is deactivated.
"Complete"	The complete channel coding is performed. The channel coding procedure can slightly vary depending on channel type, frame length and data rate.
"Without Interleaving"	Except for the block interleaver, the whole channel coding procedure is carried out.
"Interleaving Only"	In this mode, only block interleaver is used for coding.

Remote command:

[\[:SOURCE<hw>\]:BB:C2K:MSTation<st>:CCODing:MODE](#) on page 147

LC Mask (hex) - MS

Enters the mask of the long-code generator in hexadecimal form.

The long-code mask is a 42-bit value. The mask serves for channel-specific and user-specific scrambling of the code channel.

Remote command:

[\[:SOURCE<hw>\]:BB:C2K:MSTation<st>:LCMask](#) on page 152

4.10.2 Power Control - MS

The "Power Control" section is where the settings for the power control bits are made.

In the uplink, the bits are used exclusively for controlling the mobile station output power by activating the "(Mis-)Use Power Control" function. Power control puncturing of the data bits of the traffic channels for controlling the base station power is not performed.

This section is only available for the traffic channel.

Data Source (Power Control) - MS

Defines the data source for the power control bits of the channel.

The following standard data sources are available:

- "All 0, All 1"
An internally generated sequence containing 0 data or 1 data.
- "PNxx"
An internally generated pseudo-random noise sequence.
- "Pattern"
An internally generated sequence according to a bit pattern.
Use the "Pattern" box to define the bit pattern.
- "Data List/Select DList"
A binary data from a data list, internally or externally generated.
Select "Select DList" to access the standard "Select List" dialog.
 - Select the "Select Data List > navigate to the list file *.dm_iqd > Select" to select an existing data list.
 - Use the "New" and "Edit" functions to create internally new data list or to edit an existing one.
 - Use the standard "File Manager" function to transfer external data lists to the instrument.

See also "Main Dialog > Data List Management".

Remote command:

[\[:SOURce<hw>\]:BB:C2K:MSTation<st>:TPC:DATA](#) on page 154

[\[:SOURce<hw>\]:BB:C2K:MSTation<st>:TPC:DATA:PATTErn](#) on page 155

[\[:SOURce<hw>\]:BB:C2K:MSTation<st>:TPC:DATA:DSELEct](#) on page 154

Read Out Mode (Power Control) - MS

Defines a read-out mode of power control bits.

Together with the parameter [Misuse for Output Power Control - MS](#), this parameter can also be used to generate various output power profiles.

- | | |
|--------------------|--|
| "Continuous" | The power control bits are used cyclically. |
| "Single + All 0" | The power control bits are used once and then the power control sequence is continued with 0 bits. |
| "Single + All 1" | The power control bits are used once and then the power control sequence is continued with 1 bit. |
| "Single + Alt. 01" | The power control bits are used once and then the power control sequence is continued with 0 bits and 1 bit alternately. |
| "Single + Alt. 10" | The power control bits are used once and then the power control sequence is continued with 1 bit and 0 bits alternately. |

Remote command:

[\[:SOURce<hw>\]:BB:C2K:MSTation<st>:TPC:READ](#) on page 156

Misuse for Output Power Control - MS

Activates "(Mis-) Use" of the power control data.

In the uplink, the power control bits are used exclusively for controlling the mobile station output power. Power control puncturing is not defined for controlling the BS power.

If "(Mis-) Use for Output Power Control" is activated, the specified pattern is used to vary the intrinsic transmit power over time. Every 1.25 ms (800 Hz) a bit of this pattern is removed in order to increase (bit = "1") or reduce (bit = "0") the channel power by the specified "Power Step". The upper limit is 0 dB and the lower limit -80 dB.

The following envelope is produced with the settings:

- Channel power = 0 dB
- Power step = 1.0 dB
- Pattern = "001110100000011"
- "TPC Read Out Mode = Continuous"

Note: The first bit is assigned to the first power control section. In this first section, the start power specified in the channel table is always used. Only in the next power control section (with the second power control bit) will the defined power change be effective.

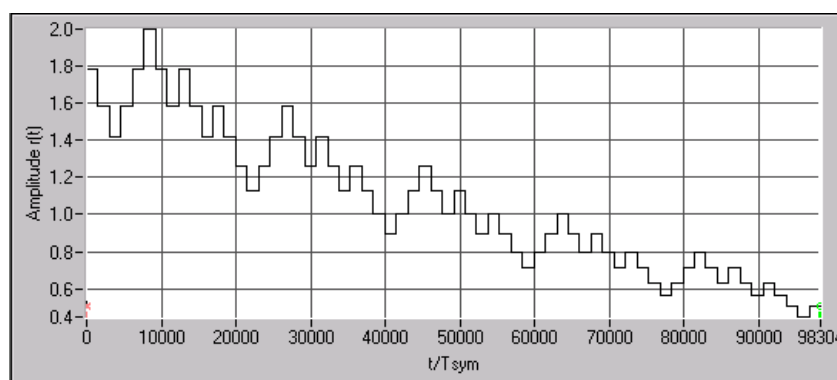

Figure 4-6: Dynamic change of channel power (continuous)

Remote command:

`[:SOURce<hw>] :BB:C2K:MSTation<st>:TPC:MISuse` on page 155

Power Step - MS

Sets the step width of the power change in dB for "(Mis-) use TPC for output power control".

Remote command:

`[:SOURce<hw>] :BB:C2K:MSTation<st>:TPC:PSTep` on page 156

4.10.3 Channel Table - MS

The "channel table" is located in the lower part of the dialog. The channel table is where the individual channel parameters are set.

The structure of the channel table depends on the selected operating mode and - for the traffic channel - on the selected radio configuration. Also, for the traffic channels, the indicated values and the settings are specific for the selected radio configuration.

In uplink, the employed Walsh code is determined by the radio configuration and cannot be chosen.

The following combinations between the operating modes of the four mobile stations are allowed:

	Traffic, RC1 & RC 2	Traffic, RC3 & RC 4	Access	Enhanced access	Common Control
Traffic, RC1 & RC 2	X		X		
Traffic, RC3 & RC 4		X		X	X
Access	X		X		
Enhanced access		X		X	X
Common control		X		X	X

Channel Number- MS

Displays the channel number.

All channels of the selected operating mode are listed. The channels are switched on and off with the "On/Off" button in the "State" column.

Remote command:

n.a.

Channel Type - MS

Indicates the channel type (see [Table 4-3](#)). The possible channel types depend on the selected operating mode of the mobile station.

Table 4-3: List of supported channel types

Short form	Name	Function
Traffic		
R-PICH	Reverse Pilot Channel	Provides the capabilities for coherent detection.
R-DCCH	Reverse Dedicated Control Channel	Transports mobile-specific control information.
R-FCH	Reverse Fundamental Channel	Similar to F-FCH; designed to transport dedicated data.
R-SCH	Reverse Supplemental Channel (RC 3...5)	Allocated dynamically to meet a required data rate.
R-SCCH	Reverse Supplemental Code Channel (RC 1 / 2)	Allocated dynamically to meet a required data rate.
Access		
R-ACH	Reverse Access Channel	Required connection set up between the mobile station and the base station.
Enhanced Access		

Short form	Name	Function
R-EACH	Reverse Enhanced Access Channel	Required connection set up between the mobile station and the base station.
R-PICH	Reverse Pilot Channel	Provides the capabilities for coherent detection.
Common Control		
R-CCCH	Reverse Common Control Channel	Similar to R-ACH but it is meant to transport control information.

Remote command:

`[:SOURCE<hw>] :BB:C2K:MSTation<st>:CHANNEL<ch>:TYPE?` on page 151

Frame Length - MS

Sets the frame length of the channel. For the traffic channels, the indicated value is specific for the selected radio configuration.

The value range depends on the channel type and the selected radio configuration. The frame length of some channels is fixed. The maximum frame length is 80 ms, the minimum frame length is 5 ms.

The frame length affects the data rates that are possible within a channel. If a frame length is changed so that the set data rate becomes invalid, the next permissible value is automatically set.

Remote command:

`[:SOURCE<hw>] :BB:C2K:MSTation<st>:CHANNEL<ch>:FLENGTH` on page 150

Data Rate - MS

Sets the data rate of the channel. For the traffic channels, the indicated value is specific for the selected radio configuration.

The R&S Signal Generator supports all data rates between 1.2 kbps and 1,036.8 kbps defined in the standard.

The value range depends on the frame length. If one of these parameters is changed so that the set data rate becomes invalid, the next permissible value is automatically set.

Remote command:

`[:SOURCE<hw>] :BB:C2K:MSTation<st>:CHANNEL<ch>:DATA:RATE`
on page 149

Walsh - MS

Assigns the Walsh code to the channel (see [Chapter 3.9, "Spreading - Uplink"](#), on page 15). For the traffic channels, the indicated value is specific for the selected radio configuration.

The code channel is spread with the set Walsh code (spreading code). The Walsh codes to be used are specified by the standard and cannot be chosen.

Remote command:

`[:SOURCE<hw>] :BB:C2K:MSTation<st>:CHANNEL<ch>:WCODE?` on page 152

Spread- MS

Indication of the spreading factor of the channel. For the traffic channels, the indicated value is specific for the selected radio configuration.

The spreading factor corresponds to the length of the employed Walsh code. The Walsh codes to be used are specified by the standard and cannot be chosen.

Remote command:

`[:SOURCE<hw>] :BB:C2K:MSTation<st>:CHANnel<ch>:SPReading?`

on page 150

Power - MS

Enters the channel power in dB. For the traffic channels, the set value is specific for the selected radio configuration.

The power entered is relative to the power's output of the other channels. If "Adjust Total Power to 0 dB" is executed (top level of the CDMA2000 dialog), all the power data is relative to 0 dB.

The set power value is also the start power of the channel for "Misuse For Output Power Control".

Note: The maximum channel power of 0 dB applies to non-blanked channels (duty cycle 100%). With blanked channels, the maximum value can be increased (by "Adjust Total Power") to values greater than 0 dB.

Remote command:

`[:SOURCE<hw>] :BB:C2K:MSTation<st>:CHANnel<ch>:POWER` on page 150

Data - MS

Selects data source. For the traffic channels, the set value is specific for the selected radio configuration.

The following standard data sources are available:

- "All 0, All 1"
An internally generated sequence containing 0 data or 1 data.
- "PNxx"
An internally generated pseudo-random noise sequence.
- "Pattern"
An internally generated sequence according to a bit pattern.
Use the "Pattern" box to define the bit pattern.
- "Data List/Select DList"
A binary data from a data list, internally or externally generated.
Select "Select DList" to access the standard "Select List" dialog.
 - Select the "Select Data List > navigate to the list file *.dm_iqd > Select" to select an existing data list.
 - Use the "New" and "Edit" functions to create internally new data list or to edit an existing one.
 - Use the standard "File Manager" function to transfer external data lists to the instrument.

See also "Main Dialog > Data List Management".

Remote command:

[:SOURce<hw>] :BB:C2K:MSTation<st>:CHANnel<ch>:DATA on page 147

[:SOURce<hw>] :BB:C2K:MSTation<st>:CHANnel<ch>:DATA:PATtern
on page 149

[:SOURce<hw>] :BB:C2K:MSTation<st>:CHANnel<ch>:DATA:DSElect
on page 148

Channel State - MS

Activates/deactivates the channel. For the traffic channels, the indicated value is specific for the selected radio configuration.

Remote command:

[:SOURce<hw>] :BB:C2K:MSTation<st>:CHANnel<ch>:STATe on page 151

5 Remote-Control Commands

The following commands are required to perform signal generation with the CDMA2000 options in a remote environment. We assume that the R&S Signal Generator has already been set up for remote operation in a network as described in the R&S Signal Generator documentation. Knowledge of the remote control operation and the SCPI command syntax is assumed.



Conventions used in SCPI command descriptions

For a description of the conventions used in the remote command descriptions, see section "Remote Control Commands" in the R&S Signal Generator operating manual.

The commands in the `SOURCE:BB:C2K` subsystem are described in several sections, separated into general remote commands, commands for base station settings and commands for mobile station settings.

Common suffixes

The following common suffixes are used in remote commands:

Suffix	Value range	Description
<code>SOURCE<hw></code>	[1] 2	available baseband signals
<code>OUTPUT<ch></code>	1 .. 4	available markers R&S SMBV supports two markers
<code>EXTERNAL<ch></code>	1 2	external trigger connectors
<code>BSTATION<st></code>	[1] 2 3 4	base station
<code>CGRoup<di0></code> <code>COFFset<ch></code>	0 [1]..8 [1]..13	See "Suffixes" on page 112
<code>MSTATION<st></code>	[1] 2 3 4	mobile station
<code>CHANNEL<ch></code>	0 [1]..8	uplink channel

Placeholder <root>

For commands that read out or save files in the default directory, the default directory is set using command `MMEM:CDIRECTORY`. The examples in this description use the placeholder `<root>` in the syntax of the command.

- `D:\` - for selecting the internal hard disk of a Windows instrument
- `E:\` - for selecting the memory stick which is inserted at the USB interface of a Windows instrument
- `/var/user/` - for selecting the internal flash card of a Linux instrument
- `/usb/` - for selecting the memory stick which is inserted at the USB interface of a Linux instrument.



Tasks (in manual or remote operation) that are also performed in the base unit in the same way are not described here.

In particular, this includes:

- Managing settings and data lists, i.e. storing and loading settings, creating and accessing data lists, accessing files in a particular directory, etc.
- Information on regular trigger, marker and clock signals as well as filter settings, if appropriate.
- General instrument configuration, such as configuring networks and remote operation
- Using the common status registers

For a description of such tasks, see the R&S Signal Generator operating manual.

The following commands specific to the CDMA2000 are described here:

• Primary Commands	86
• Filter/Clipping Settings	93
• Trigger Settings	98
• Marker Settings	102
• Clock Settings	105
• Predefined Settings	107
• Base Stations Settings	112
• Mobile Station Settings	144

5.1 Primary Commands

[:SOURce<hw>]:BB:C2K:COPY:COFFset	87
[:SOURce<hw>]:BB:C2K:COPY:DESTination	87
[:SOURce<hw>]:BB:C2K:COPY:EXECute	87
[:SOURce<hw>]:BB:C2K:COPY:SOURce	88
[:SOURce<hw>]:BB:C2K:CRATe?	88
[:SOURce<hw>]:BB:C2K:CRATe:VARiation	89
[:SOURce<hw>]:BB:C2K:IQSWap[:STATe]	89
[:SOURce<hw>]:BB:C2K:LINK	89
[:SOURce<hw>]:BB:C2K:POWer:ADJust	90
[:SOURce<hw>]:BB:C2K:POWer[:TOTal]?	90
[:SOURce<hw>]:BB:C2K:PRESet	90
[:SOURce<hw>]:BB:C2K:SETTing:CATalog?	90
[:SOURce<hw>]:BB:C2K:SETTing:DELeTe	91
[:SOURce<hw>]:BB:C2K:SETTing:LOAD	91
[:SOURce<hw>]:BB:C2K:SETTing:STORe	91
[:SOURce<hw>]:BB:C2K:SETTing:STORe:FAST	92
[:SOURce<hw>]:BB:C2K:SLENgth	92
[:SOURce<hw>]:BB:C2K:STATe	92
[:SOURce<hw>]:BB:C2K:WAVeform:CREate	93
[:SOURce]:BB:C2K:VERSion?	93

[:SOURce<hw>]:BB:C2K:COPY:COFFset <COffset>

The command sets the offset for the Walsh code in the destination base station. The minimum value is 0 (Walsh codes are identical), the maximum value is 255.

This command is only available in the downlink (SOUR:BB:C2K:LINK FORW/DOWN).

Parameters:

<COffset> integer
 Range: 0 to 255
 Increment: 1
 *RST: 0

Example:

BB:C2K:COPY:COFF 10
 the Walsh code is shifted by 10 when the source base station is copied to the destination base station.

Manual operation: See "[Copy ...](#)" on page 29

[:SOURce<hw>]:BB:C2K:COPY:DESTination <Destination>

The command selects the station to which data is to be copied. Whether the data is copied to a base station or a mobile station depends on which transmission direction is selected (command C2K:LINK UP | DOWN).

Parameters:

<Destination> 1 | 2 | 3 | 4
 Range: 1 to 4
 *RST: 2

Example:

BB:C2K:LINK DOWN
 selects the downlink transmit direction (base station to mobile station).
 BB:C2K:COPY:SOUR 1
 selects base station 1 as the source.
 BB:C2K:COPY:DEST 4
 selects base station 4 as the destination.
 BB:C2K:COPY:EXEC
 starts copying the parameter set of base station 1 to base station 4.

Manual operation: See "[Copy ...](#)" on page 29

[:SOURce<hw>]:BB:C2K:COPY:EXECute

The command starts the copy process. The dataset of the source station is copied to the destination station. Whether the data is copied to a base station or a mobile station depends on which transmission direction is selected (command :BB:C2K:LINK UP | DOWN).

- Example:** `BB:C2K:COPY:EXEC`
starts copying the parameter set of the selected source station to the selected destination station.
- Usage:** Event
- Manual operation:** See "[Copy ...](#)" on page 29

[:SOURCE<hw>]:BB:C2K:COPY:SOURCE <Source>

The command selects the station that has data to be copied. Whether the station copied is a base or mobile station depends on which transmission direction is selected (command `C2K:LINK UP | DOWN`).

Parameters:

<Source> 1 | 2 | 3 | 4
Range: 1 to 4
*RST: 1

- Example:** `BB:C2K:LINK UP`
selects the uplink transmit direction (mobile station to base station).
- `BB:C2K:COPY:SOUR 1`
selects mobile station 1 as the source.
- `BB:C2K:COPY:DEST 4`
selects mobile station 4 as the destination.
- `BB:C2K:COPY:EXEC`
starts copying the parameter set of mobile station 1 to mobile station 4.

Manual operation: See "[Copy ...](#)" on page 29

[:SOURCE<hw>]:BB:C2K:CRATE?

The command queries the spreading rate. The output chip rate which determines the rate of the spread symbols as is used for signal output can be set with the command `SOUR:BB:C2K:CRAT:VAR`.

Return values:

<CRate> R1M2
*RST: R1M2

- Example:** `BB:C2K:CRAT?`
queries the system chip rate.
Response: R1M2
the system chip rate is 1.2288 Mcps.

Usage: Query only

Manual operation: See "[Spreading Rate](#)" on page 26

[[:SOURce<hw>]:BB:C2K:CRATe:VARiatiOn <Variation>

Sets the output chip rate.

The output chip rate changes the output clock and the modulation bandwidth, as well as the synchronization signals that are output. It does not affect the calculated chip sequence.

Parameters:

<Variation> float
 Range: 400 to 5E6
 Increment: 1E-3
 *RST: 1.2288E6

Example: BB:C2K:CRAT:VAR 4086001
 sets the chip rate to 4.08 Mcps.

Manual operation: See ["Chip Rate Variation"](#) on page 32

[[:SOURce<hw>]:BB:C2K:IQSWap[:STATe] <State>

This command inverts the Q-part of the baseband signal if set to ON. The signal on the baseband outputs meets the cdma2000 standard. In order to generate an RF signal that conforms to the standard, the "I/Q Swap" function in the "I/Q Modulator" menu must be enabled ("On") (SOURce:IQ:SWAP ON).

Parameters:

<State> 0 | 1 | OFF | ON
 *RST: OFF

Example: BB:C2K:IQSW:STAT ON
 inverts the Q-part of the baseband signal.

Manual operation: See ["Invert Q for Correct Baseband Output"](#) on page 35

[[:SOURce<hw>]:BB:C2K:LINK <Link>

The command defines the transmission direction. The signal either corresponds to that of a base station (FORWard | DOWN) or that of a mobile station (REVerse | UP).

Parameters:

<Link> DOWN | UP | FORWard | REVerse
 *RST: DOWN

Example: BB:C2K:LINK DOWN
 the transmission direction selected is base station to mobile station. The signal corresponds to that of a base station.

Manual operation: See ["Link Direction"](#) on page 26

[:SOURce<hw>]:BB:C2K:POWER:ADJust

The command sets the power of the active channels in such a way that the total power of the active channels is 0 dB. This does not change the power ratio among the individual channels.

Example: `BB:C2K:POW:ADJ`
The total power of the active channels is set to 0 dB, the power ratio among the individual channels is unchanged.

Usage: Event

Manual operation: See "[Adjust Total Power to 0dB](#)" on page 29

[:SOURce<hw>]:BB:C2K:POWER[:TOTal]?

The command queries the total power of the active channels. After "Power Adjust", this power corresponds to 0 dB.

Return values:
<Total> float
Range: -80 dB to 30 dB
Increment: 0.01 dB
*RST: 0 dB

Example: `BB:C2K:POW?`
queries the total power of the active channels.
Response: `-22.5`
the total power is -25 dB.

Usage: Query only

Manual operation: See "[Total Power](#)" on page 30

[:SOURce<hw>]:BB:C2K:PRESet

Sets the parameters of the digital standard to their default values (*RST values specified for the commands).

Not affected is the state set with the command `SOURce<hw>:BB:C2K:STATe`.

Example: `SOURce1:BB:C2K:PRESet`

Usage: Event

Manual operation: See "[Set to Default](#)" on page 23

[:SOURce<hw>]:BB:C2K:SETTing:CATalog?

Queries the files with settings in the default directory. Listed are files with the file extension `*.cdma2k`.

For general information on file handling in the default and in a specific directory, see section "MMEMory Subsystem" in the R&S SMx/AMU operating manual.

Return values:

<Catalog> <filename1>,<filename2>,...

Returns a string of filenames separated by commas.

Example:

```
MMEM:CDIR '<root>cdma'
SOURCE1:BB:C2K:SETTING:CATALOG?
// Response: "cdma_up", "cdma_down"
SOURCE1:BB:C2K:SETTING:DELETE "cdma_down"
SOURCE1:BB:C2K:SETTING:LOAD "cdma_up"
```

Usage: Query only

Manual operation: See "Save/Recall ..." on page 24

[:SOURCE<hw>]:BB:C2K:SETTING:DELETE <Filename>

Deletes the selected file from the default or the specified directory. Deleted are files with extension *.cdma2k.

Setting parameters:

<Filename> string

Example: See [:SOURCE<hw>]:BB:C2K:SETTING:CATALOG? on page 90

Usage: Setting only

Manual operation: See "Save/Recall ..." on page 24

[:SOURCE<hw>]:BB:C2K:SETTING:LOAD <Filename>

Loads the selected file from the default or the specified directory. Loaded are files with extension *.cdma2k.

Setting parameters:

<Filename> "<filename>"

Filename or complete file path; file extension can be omitted

Example: See [:SOURCE<hw>]:BB:C2K:SETTING:CATALOG? on page 90

Usage: Setting only

Manual operation: See "Save/Recall ..." on page 24

[:SOURCE<hw>]:BB:C2K:SETTING:STORE <Filename>

Stores the current settings into the selected file; the file extension (*.cdma2k) is assigned automatically.

Setting parameters:

<Filename> string

Filename or complete file path

Example: BB:C2K:SETT:STOR 'CDMA_UP'
Usage: Setting only
Manual operation: See "[Save/Recall ...](#)" on page 24

[[:SOURce<hw>]:BB:C2K:SETTing:STORe:FAST <Fast>

Determines whether the instrument performs an absolute or a differential storing of the settings.

Enable this function to accelerate the saving process by saving only the settings with values different to the default ones.

Note: This function is not affected by the "Preset" function.

Parameters:

<Fast> 0 | 1 | OFF | ON
 *RST: ON

Manual operation: See "[Save/Recall ...](#)" on page 24

[[:SOURce<hw>]:BB:C2K:SLENgth <SLength>

Sets the sequence length of the arbitrary waveform component of the CDMA2000 signal in the number of frames.

Parameters:

<SLength> integer
 Range: 1 to max
 *RST: 1

Example: BB:C2K:SLEN 10
 sets the sequence length to 10 frames.

Manual operation: See "[Sequence Length ARB](#)" on page 34

[[:SOURce<hw>]:BB:C2K:STATe <State>

Activates the standard and deactivates all the other digital standards and digital modulation modes in the same path.

Parameters:

<State> 0 | 1 | OFF | ON
 *RST: 0

Example: SOURce1:BB:C2K:STATe ON

Manual operation: See "[State](#)" on page 23

[[:SOURce<hw>]:BB:C2K:WAVEform:CREate <Filename>

This command creates a waveform using the current settings of the "CDMA2000" menu. The file name is entered with the command. The file is stored with the predefined file extension *.wv. The file name and the directory it is stored in are user-definable.

Setting parameters:

<Filename> string

Example:

```
MMEM:CDIR "<root>waveform"
sets the default directory to <root>waveform.
BB:C2K:WAV:CRE "cdma_bs"
creates the waveform file cdma_bs.wv in the default directory.
```

Usage: Setting only

Manual operation: See ["Generate Waveform File"](#) on page 25

[[:SOURce]:BB:C2K:VERSion?

The command queries the version of the CDMA standard underlying the definitions.

Return values:

<Version> string

Example:

```
BB:C2K:VERS?
queries the CDMA version.
Response: Release C
CDMA Release 5
```

Usage: Query only

Manual operation: See ["CDMA 2000 Version"](#) on page 25

5.2 Filter/Clipping Settings

5.2.1 Filter Settings

[:SOURce<hw>]:BB:C2K:FILTer:TYPe.....	94
[:SOURce<hw>]:BB:C2K:FILTer:PARAmeter:APCO25.....	94
[:SOURce<hw>]:BB:C2K:FILTer:PARAmeter:COSSine.....	94
[:SOURce<hw>]:BB:C2K:FILTer:PARAmeter:GAUSS.....	94
[:SOURce<hw>]:BB:C2K:FILTer:PARAmeter:LPASS.....	95
[:SOURce<hw>]:BB:C2K:FILTer:PARAmeter:LPASSEVM.....	95
[:SOURce<hw>]:BB:C2K:FILTer:PARAmeter:PGAuss.....	95
[:SOURce<hw>]:BB:C2K:FILTer:PARAmeter:RCOSSine.....	96
[:SOURce<hw>]:BB:C2K:FILTer:PARAmeter:SPHase.....	96

[:SOURce<hw>]:BB:C2K:FILTer:TYPe <Type>

The command selects the filter type.

Parameters:

<Type> RCOSine | COSine | GAUSs | LGAuss | CONE | COF705 |
 COEqualizer | COFequalizer | C2K3x | APCO25 | SPHase |
 RECTangle | PGAuss | LPASs | DIRac | ENPShape |
 EWPSshape | LPASSEVM
 *RST: Downlink:COEF; Uplink: CONE

Example:

BB:C2K:FILT:TYPE CONE
 sets the filter type CdmaOne. This filter type is defined by the
 standard for the uplink.

Manual operation: See ["Filter"](#) on page 31

[:SOURce<hw>]:BB:C2K:FILTer:PARAMeter:APCO25 <Apco25>

The command sets the roll-off factor for filter type APCO25.

Parameters:

<Apco25> float
 Range: 0.05 to 0.99
 Increment: 0.01
 *RST: 0.20

Example:

BB:C2K:FILT:PAR:APCO25 0.2
 sets the roll-off factor to 0.2 for filter type APCO25.

Manual operation: See ["Roll Off Factor or BxT"](#) on page 31

[:SOURce<hw>]:BB:C2K:FILTer:PARAMeter:COSine <Cosine>

The command sets the roll-off factor for the Cosine filter type.

Parameters:

<Cosine> float
 Range: 0.00 to 1.0
 Increment: 0.01
 *RST: 0.35

Example:

BB:C2K:FILT:PAR:COS 0.35
 sets the roll-off factor to 0.35 for filter type Cosine.

Manual operation: See ["Roll Off Factor or BxT"](#) on page 31

[:SOURce<hw>]:BB:C2K:FILTer:PARAMeter:GAUSs <Gauss>

The command sets the roll-off factor for the Gauss filter type.

Parameters:

<Gauss> float
 Range: 0.15 to 2.5
 Increment: 0.01
 *RST: 0.5

Example:

BB:C2K:FILT:PAR:GAUS 0.5
 sets B x T to 0.5 for the Gauss filter type.

Manual operation: See "[Roll Off Factor or BxT](#)" on page 31

[:SOURCE<hw>]:BB:C2K:FILT:PAR:LPASS <LPass>

The command sets the cut-off frequency factor for the Lowpass (ACP Opt.) filter type.

Parameters:

<LPass> float
 Range: 0.05 to 2
 Increment: 0.01
 *RST: 0.5

Example:

BB:C2K:FILT:PAR:LPAS 0.5
 The cut-off frequency factor is set to 0.5.

Manual operation: See "[Cutoff Frequency Factor](#)" on page 32

[:SOURCE<hw>]:BB:C2K:FILT:PAR:LPASSEVM <LPassEvm>

The command sets the cut-off frequency factor for the Lowpass (EVM Opt.) filter type.

Parameters:

<LPassEvm> float
 Range: 0.05 to 2
 Increment: 0.01
 *RST: 0.5

Example:

BB:C2K:FILT:PAR:LPASSEVM 0.5
 The cut-off frequency factor is set to 0.5.

Manual operation: See "[Cutoff Frequency Factor](#)" on page 32

[:SOURCE<hw>]:BB:C2K:FILT:PAR:PGAUSS <PGauss>

The command sets the roll-off factor for the Pure Gauss filter type.

Parameters:

<PGauss> float
 Range: 0.15 to 2.5
 Increment: 0.01
 *RST: 0.5

Example: `BB:C2K:FILT:PAR:GAUS 0.5`
sets B x T to 0.5 for the Pure Gauss filter type.

Manual operation: See ["Roll Off Factor or BxT"](#) on page 31

[:SOURce<hw>]:BB:C2K:FILT:PAR:RCOSine <RCosine>

The command sets the roll-off factor for the Root Cosine filter type.

Parameters:

<RCosine> float
Range: 0.00 to 1.0
Increment: 0.01
*RST: 0.22

Example: `BB:C2K:FILT:PAR:RCOS 0.22`
sets the roll-off factor to 0.22 for filter type Root Cosine.

Manual operation: See ["Roll Off Factor or BxT"](#) on page 31

[:SOURce<hw>]:BB:C2K:FILT:PAR:SPHase <SPHase>

The command sets B x T for the Split Phase filter type.

Parameters:

<SPHase> float
Range: 0.15 to 2.5
Increment: 0.01
*RST: 2.00

Example: `BB:C2K:FILT:PAR:SPH 0.5`
sets B x T to 0.5 for the Split Phase filter type.

Manual operation: See ["Roll Off Factor or BxT"](#) on page 31

5.2.2 Clipping Settings

[:SOURce<hw>]:BB:C2K:CLIPping:LEVel	96
[:SOURce<hw>]:BB:C2K:CLIPping:MODE	97
[:SOURce<hw>]:BB:C2K:CLIPping:STATE	97

[:SOURce<hw>]:BB:C2K:CLIPping:LEVel <Level>

The command sets the limit for level clipping (Clipping). This value indicates at what point the signal is clipped. It is specified as a percentage, relative to the highest level. 100% indicates that clipping does not take place.

Level clipping is activated with the command `[:SOURce<hw>]:BB:C2K:CLIPping:STATE`

Parameters:

<Level> integer
 Range: 1 PCT to 100
 Increment: 1
 *RST: 100 PCT

Example:

BB:C2K:CLIP:LEV 80PCT
 sets the limit for level clipping to 80% of the maximum level.
 BB:C2K:CLIP:STAT ON
 activates level clipping.

Manual operation: See "[Clipping Level](#)" on page 34

[:SOURce<hw>]:BB:C2K:CLIPping:MODE <Mode>

The command sets the method for level clipping (Clipping).

Parameters:

<Mode> VECTor | SCALar
VECTor
 The reference level is the amplitude $|i+jq|$
SCALar
 The reference level is the absolute maximum of the I and Q values.
 *RST: VECTor

Example:

BB:C2K:CLIP:MODE SCAL
 selects the absolute maximum of all the I and Q values as the reference level.
 BB:C2K:CLIP:LEV 80PCT
 sets the limit for level clipping to 80% of this maximum level.
 BB:C2K:CLIP:STAT ON
 activates level clipping.

Manual operation: See "[Clipping Mode](#)" on page 34

[:SOURce<hw>]:BB:C2K:CLIPping:STATe <State>

The command activates level clipping (Clipping). The value is defined with the command `[:SOURce<hw>]:BB:C2K:CLIPping:LEVel`, the mode of calculation with the command `[:SOURce<hw>]:BB:C2K:CLIPping:MODE`.

Parameters:

<State> 0 | 1 | OFF | ON
 *RST: OFF

Example:

BB:C2K:CLIP:STAT ON
 activates level clipping.

Manual operation: See "[Clipping State](#)" on page 32

5.3 Trigger Settings

EXternal<ch>

The numeric suffix to EXternal<ch> distinguishes between the external trigger via the TRIGGER 1 (suffix 1) and TRIGGER 2 (suffix 2) connector.

Example: Trigger configuration

```
SOURce1:BB:C2K:TRIGger:SOURce INTernal
SOURce1:BB:C2K:TRIGger:SEQuence ARETrigger
SOURce1:BB:C2K:STAT ON
SOURce1:BB:C2K:TRIGger:EXECute
SOURce1:BB:C2K:TRIGger:ARM:EXECute
SOURce1:BB:C2K:TRIGger:RMODE?
// stopped
SOURce1:BB:C2K:TRIGger:EXECute
SOURce1:BB:C2K:TRIGger:RMODE?
// run

// SOURce1:BB:C2K:TRIGger:SEQuence SING
// SOURce1:BB:C2K:TRIGger:SLUNit SEQ
// SOURce1:BB:C2K:TRIGger:SLENgth 2

// SOURce1:BB:C2K:TRIGger:SEQuence AAUT
// SOURce1:BB:C2K:TRIGger:SOURce EXT
// SOURce1:BB:C2K:TRIGger:EXTernal:SYNChronize:OUTPut 1
// SOURce1:BB:C2K:TRIGger:EXTernal1:INHibit 100
// SOURce1:BB:C2K:TRIGger:EXTernal1:DELAy 10
```

[:SOURce<hw>]:BB:C2K[:TRIGger]:SEQuence.....	98
[:SOURce<hw>]:BB:C2K:TRIGger:SOURce.....	99
[:SOURce<hw>]:BB:C2K:TRIGger:ARM:EXECute.....	99
[:SOURce<hw>]:BB:C2K:TRIGger:EXECute.....	99
[:SOURce<hw>]:BB:C2K:TRIGger:EXTernal:SYNChronize:OUTPut.....	99
[:SOURce<hw>]:BB:C2K:TRIGger:OBASeband:DELAy.....	100
[:SOURce<hw>]:BB:C2K:TRIGger:OBASeband:INHibit.....	100
[:SOURce<hw>]:BB:C2K:TRIGger[:EXTernal<ch>]:DELAy.....	100
[:SOURce<hw>]:BB:C2K:TRIGger[:EXTernal<ch>]:INHibit.....	101
[:SOURce<hw>]:BB:C2K:TRIGger:RMODE?.....	101
[:SOURce<hw>]:BB:C2K:TRIGger:SLENgth.....	101
[:SOURce<hw>]:BB:C2K:TRIGger:SLUNit.....	102

[:SOURce<hw>]:BB:C2K[:TRIGger]:SEQuence <Sequence>

Selects the trigger mode:

- AUTO = auto
- RETRigger = retrigger
- AAUTo = armed auto
- ARETrigger = armed retrigger

- SINGle = single

Parameters:

<Sequence> AUTO | RETRigger | AAUTo | ARETrigger | SINGle
 *RST: AUTO

Example: See [Example "Trigger configuration"](#) on page 98

Manual operation: See ["Trigger Mode"](#) on page 36

[:SOURce<hw>]:BB:C2K:TRIGger:SOURce <Source>

Selects the trigger source:

- INTernal: manual trigger or *TRG.
- EXTernal|BEXTernal: trigger signal on the TRIGGER 1/2 connector.
- OBASeband: trigger signal from the other path

Parameters:

<Source> INTernal|OBASeband|BEXTernal|EXTernal
 *RST: INTernal

Example: SOURce1:BB:C2K:TRIGger:SOURce EXTernal
 sets external triggering via the TRIGGER 1 connector.

Manual operation: See ["Trigger Source"](#) on page 38

[:SOURce<hw>]:BB:C2K:TRIGger:ARM:EXECute

Stops signal generation; a subsequent trigger event restarts signal generation.

Example: See [Example "Trigger configuration"](#) on page 98

Usage: Event

Manual operation: See ["Arm"](#) on page 37

[:SOURce<hw>]:BB:C2K:TRIGger:EXECute

Executes a trigger.

Example: See [Example "Trigger configuration"](#) on page 98

Usage: Event

Manual operation: See ["Execute Trigger"](#) on page 26

[:SOURce<hw>]:BB:C2K:TRIGger:EXTernal:SYNChronize:OUTPut <Output>

Enables/disables output of the signal synchronous to the external trigger event.

For R&S SMBV instruments:

See also ["Sync. Output to External Trigger"](#) on page 38 for a detailed description of the applications of this setting.

Parameters:

<Output> 0 | 1 | OFF | ON
 *RST: 1

Example: See [Example "Trigger configuration"](#) on page 98

Manual operation: See ["Sync. Output to External Trigger"](#) on page 38

[:SOURCE<hw>]:BB:C2K:TRIGGER:OBASband:DELAY <Delay>

Sets the trigger delay (expressed as a number of chips) for triggering by the trigger signal from the second path (two-path instruments only).

Parameters:

<Delay> float
 Range: 0 to 65535
 Increment: 0.01
 *RST: 0

Example: BB:C2K:TRIG:SOUR OBAS
 sets for path A the internal trigger executed by the trigger signal from the second path (path B).
 BB:C2K:TRIG:OBAS:DEL 50
 sets a delay of 50 symbols for the trigger.

Manual operation: See ["Trigger Delay"](#) on page 39

[:SOURCE<hw>]:BB:C2K:TRIGGER:OBASband:INHIBIT <Inhibit>

For triggering via the other path, specifies the duration by which a restart is inhibited.

Parameters:

<Inhibit> integer
 Range: 0 to 67108863
 *RST: 0

Example: BB:C2K:TRIG:SOUR OBAS
 sets for path A the internal trigger executed by the trigger signal from the second path (path B).
 BB:C2K:TRIG:INH 200
 sets a restart inhibit for 200 chips following a trigger event.

Manual operation: See ["Trigger Inhibit"](#) on page 40

[:SOURCE<hw>]:BB:C2K:TRIGGER[:EXTERNAL<ch>]:DELAY <Delay>

The command specifies the trigger delay (expressed as a number of chips) for external triggering.

Parameters:

<Delay> float
 Range: 0 to 65535
 Increment: 0.01 chips
 *RST: 0

Example:

BB:C2K:TRIG:SOUR EXT
 sets an external trigger via the TRIGGER 1 connector.
 BB:C2K:TRIG:DEL 50
 sets a delay of 50 symbols for the trigger.

Manual operation: See ["Trigger Delay"](#) on page 39

[:SOURce<hw>]:BB:C2K:TRIGger[:EXTernal<ch>]:INHibit <Inhibit>

The command specifies the number of chips by which a restart is to be inhibited following a trigger event. This command applies only in the case of external triggering.

Parameters:

<Inhibit> integer
 Range: 0 to 67108863
 Increment: 1 chip
 *RST: 0

Example:

BB:C2K:TRIG:SOUR EXT
 selects an external trigger via the TRIGGER 1 connector.
 BB:C2K:TRIG:INH 200
 sets a restart inhibit for 200 chips following a trigger event.

Manual operation: See ["Trigger Inhibit"](#) on page 40

[:SOURce<hw>]:BB:C2K:TRIGger:RMODE?

Queries the signal generation status.

Return values:

<RMode> STOP | RUN

Example: See [Example "Trigger configuration"](#) on page 98

Usage: Query only

Manual operation: See ["Running/Stopped"](#) on page 37

[:SOURce<hw>]:BB:C2K:TRIGger:SLENgth <SLength>

Defines the length of the signal sequence that is output in the SINGLE trigger mode.

Parameters:

<SLength> integer
 Range: 1 to INT_MAX
 *RST: 98304

Example: See [Example "Trigger configuration"](#) on page 98

Manual operation: See ["Signal Duration"](#) on page 37

[:SOURce<hw>]:BB:C2K:TRIGger:SLUNit <SIUnit>

Defines the unit for the entry of the signal sequence length.

Parameters:

<SIUnit> FRAME | CHIP | SEQuence
 *RST: SEQuence

Example: See [Example "Trigger configuration"](#) on page 98

Manual operation: See ["Signal Duration Unit"](#) on page 37

5.4 Marker Settings

Example: Configure and enable standard marker signals

```
SOURce1:BB:C2K:TRIGger:OUTPut2:MODE RAT
SOURce1:BB:C2K:TRIGger:OUTPut2:ONTime 20
SOURce1:BB:C2K:TRIGger:OUTPut2:OFFTime 200
```

```
SOURce1:BB:C2K:TRIGger:OUTPut3:MODE USER
SOURce1:BB:C2K:TRIGger:OUTPut3:PERiod 100
SOURce1:BB:C2K:TRIGger:OUTPut3:DELay 1000
```

```
SOURce1:BB:C2K:TRIGger:OUTPut:DELay:FIXed 1
SOURce1:BB:C2K:TRIGger:OUTPut1:DELay:MINimum?
// 0
SOURce1:BB:C2K:TRIGger:OUTPut1:DELay:MAXimum?
// 2000
```

[:SOURce<hw>]:BB:C2K:TRIGger:OUTPut:DELay:FIXed	102
[:SOURce<hw>]:BB:C2K:TRIGger:OUTPut<ch>:DELay	103
[:SOURce<hw>]:BB:C2K:TRIGger:OUTPut<ch>:DELay:MINimum?	103
[:SOURce<hw>]:BB:C2K:TRIGger:OUTPut<ch>:DELay:MAXimum?	103
[:SOURce<hw>]:BB:C2K:TRIGger:OUTPut<ch>:MODE	103
[:SOURce<hw>]:BB:C2K:TRIGger:OUTPut<ch>:ONTime	104
[:SOURce<hw>]:BB:C2K:TRIGger:OUTPut<ch>:OFFTime	104
[:SOURce<hw>]:BB:C2K:TRIGger:OUTPut<ch>:PERiod	104

[:SOURce<hw>]:BB:C2K:TRIGger:OUTPut:DELay:FIXed <Fixed>

Restricts the marker delay setting range to the dynamic range.

Parameters:

<Fixed> 0 | 1 | OFF | ON
 *RST: 0

Example: See [Example "Configure and enable standard marker signals"](#) on page 102

Manual operation: See ["Fix marker delay to current range"](#) on page 41

[:SOURce<hw>]:BB:C2K:TRIGger:OUTPut<ch>:DELay <Delay>

Defines the delay between the signal on the marker outputs and the start of the signals.

Parameters:

<Delay> float
 Range: 0 to max
 Increment: 1E-3
 *RST: 0

Example: See [Example "Configure and enable standard marker signals"](#) on page 102

Manual operation: See ["Marker x Delay"](#) on page 41

[:SOURce<hw>]:BB:C2K:TRIGger:OUTPut<ch>:DELay:MINimum?
[:SOURce<hw>]:BB:C2K:TRIGger:OUTPut<ch>:DELay:MAXimum?

Queries the min/max marker delay.

Return values:

<Maximum> float

Example: See [Example "Configure and enable standard marker signals"](#) on page 102

Usage: Query only

Manual operation: See ["Current Range without Recalculation"](#) on page 41

[:SOURce<hw>]:BB:C2K:TRIGger:OUTPut<ch>:MODE <Mode>

Defines the signal for the selected marker output.

Parameters:

<Mode> PCGRoup | RFRame | SCFRame | SFRame | ESECond | CSPeriod | RATio | USER | TRIGger

Marker signal that marks:

PCGRoup
The start of each power control group (every 1.25 ms).

RFRame
Every 20 ms (traffic channel clock).

SCFRame
The start of each sync channel frame (every 26.6 ms).

SFRame
Every 80 ms (super frame clock).

ESECond
Every 2 s (even second mark).

CSPeriod
The start of each arbitrary waveform sequence

RATio
Off / On times

USER
The beginning of every user-defined period

TRIGger
A received internal or external trigger signal is output at the marker connector.

*RST: PCGRoup

Example: See [Example "Configure and enable standard marker signals"](#) on page 102

Manual operation: See ["Marker Mode"](#) on page 40

```
[[:SOURce<hw>]:BB:C2K:TRIGger:OUTPut<ch>:ONTime <OnTime>
[:SOURce<hw>]:BB:C2K:TRIGger:OUTPut<ch>:OFFTime <OffTime>
```

Sets the duration during which the marker output is on or off.

Parameters:

<OffTime> integer

Range: 1 to 16777215

*RST: 1

Example: See [Example "Configure and enable standard marker signals"](#) on page 102

Manual operation: See ["Marker Mode"](#) on page 40

```
[[:SOURce<hw>]:BB:C2K:TRIGger:OUTPut<ch>:PERiod <Period>
```

Sets the repetition rate for the signal at the marker outputs.

Parameters:

<Period> integer
 Range: 2 to UINT_MAX
 *RST: 2

Example: See [Example "Configure and enable standard marker signals"](#) on page 102

Manual operation: See ["Marker Mode"](#) on page 40

5.5 Clock Settings

This section lists the remote control commands, necessary to configure the clock.

[:SOURce<hw>]:BB:C2K:CLOCK:MODE	105
[:SOURce<hw>]:BB:C2K:CLOCK:MULTIPLIER	105
[:SOURce<hw>]:BB:C2K:CLOCK:SOURce	106
[:SOURce<hw>]:BB:C2K:CLOCK:SYNChronization:EXECute	106
[:SOURce<hw>]:BB:C2K:CLOCK:SYNChronization:MODE	107

[:SOURce<hw>]:BB:C2K:CLOCK:MODE <Mode>

Sets the type of externally supplied clock.

For two-path instruments, the only numerical suffix allowed for SOURce is 1, since the external clock source is permanently allocated to path A.

Parameters:

<Mode> CHIP | MCHip
 *RST: CHIP

Example: SOURce1:BB:C2K:CLOCK:MODE CHIP

Manual operation: See ["Clock Mode"](#) on page 43

[:SOURce<hw>]:BB:C2K:CLOCK:MULTIPLIER <Multiplier>

Sets the multiplier for clock type "Multiplied" (:BB:C2K:CLOCK:MODE MCHip) in the case of an external clock source.

For two-path instruments, the only numerical suffix allowed for SOURce is 1, since the external clock source is permanently allocated to path A.

Parameters:

<Multiplier> integer
 Range: 1 to 64
 *RST: 4

Example: `SOURce1:BB:C2K:CLOCK:SOURce EXTernal`
selects the external clock source.
`BB:C2K:CLOCK:MODE MCHip`
selects clock type "Multiplied", i.e. the supplied clock has a rate which is a multiple of the chip rate.
`BB:C2K:CLOCK:MULTiplier 12`
the multiplier for the external clock rate is 12.

Manual operation: See "[Clock Multiplier](#)" on page 43

[:SOURce<hw>]:BB:C2K:CLOCK:SOURce <Source>

The command selects the clock source.

For two-path instruments, selecting `EXTernal` is only possible for path A, since the external clock source is permanently allocated to path A. Selection `AINternal` is only possible for path B.

Parameters:

<Source> INTernal | EXTernal | AINTernal

INTernal

The internal clock reference is used.

EXTernal

The external clock reference is supplied to the CLOCK connector. Commands `[:SOURce<hw>]:BB:C2K:CLOCK:MODE` and `[:SOURce<hw>]:BB:C2K:CLOCK:MULTiplier` are used to enter the type of the external clock.

AINternal

The clock source of path A is used for path B.

*RST: INTernal

Example: `:BB:C2K:CLOC:SOUR EXT`
selects the external clock source. The clock is supplied via the CLOCK connector.
`BB:C2K:CLOC:MODE MCH`
selects clock type "Multiplied", i.e. the supplied clock has a rate which is a multiple of the chip rate.
`BB:C2K:CLOC:MULT 12`
the multiplier for the external clock rate is 12.

Manual operation: See "[Clock Source](#)" on page 42

[:SOURce<hw>]:BB:C2K:CLOCK:SYNChronization:EXECute

Adjusts of the instrument's settings according to the selected synchronization mode.

Example: See `[:SOURce<hw>]:BB:C2K:CLOCK:SYNChronization:MODE` on page 107

Usage: Event

Manual operation: See "[Set Synchronization Settings](#)" on page 42

[:SOURce<hw>]:BB:C2K:CLOCK:SYNChronization:MODE <Mode>

(for R&S SMBV only)

Selects the synchronization mode.

This parameter is used to enable generation of precise synchronous signal of several connected R&S SMBVs.

Note: If several instruments are connected, the connecting cables from the master instrument to the slave one and between each two consecutive slave instruments must have the same length and type. Avoid unnecessary cable length and branching points.

Parameters:

<Mode>

NONE | MASTer | SLAVe

NONE

The instrument is working in stand-alone mode.

MASTer

The instrument provides all connected instrument with its synchronization (including the trigger signal) and reference clock signal.

SLAVe

The instrument receives the synchronization and reference clock signal from another instrument working in a master mode.

*RST: NONE

Example:

BB:C2K:CLOC:SYN:MODE MAST

The instrument is configured to work as a master one.

BB:C2K:CLOC:SYN:EXEC

All synchronization's settings are set accordingly.

Manual operation: See "[Sync. Mode](#)" on page 42

5.6 Predefined Settings

The R&S Signal Generator gives you the opportunity to generate predefined test settings for base station 1. These predefined settings enable the creation of highly complex scenarios for the downlink by presetting the channel table of base station 1. The settings take effect only after execution of command `[:SOURce<hw>]:BB:C2K:PPARameter:EXECute`.

`PPARameter:EXECute`.

<code>[:SOURce<hw>]:BB:C2K:PPARameter:CRESt</code>	108
<code>[:SOURce<hw>]:BB:C2K:PPARameter:EXECute</code>	108
<code>[:SOURce<hw>]:BB:C2K:PPARameter:PCHannel[:STATe]</code>	108
<code>[:SOURce<hw>]:BB:C2K:PPARameter:PICHannel[:STATe]</code>	109
<code>[:SOURce<hw>]:BB:C2K:PPARameter:RCONfiguration</code>	109
<code>[:SOURce<hw>]:BB:C2K:PPARameter:SCHannel[:STATe]</code>	109
<code>[:SOURce<hw>]:BB:C2K:PPARameter:TCHannel:COUNT</code>	110
<code>[:SOURce<hw>]:BB:C2K:PPARameter:TCHannel:DATA:RATE</code>	110
<code>[:SOURce<hw>]:BB:C2K:PPARameter:TCHannel:DCCHannel[:STATe]</code>	111

<code>[:SOURce<hw>]:BB:C2K:PPARameter:TCHannel:FCHannel[:STATe]</code>	111
<code>[:SOURce<hw>]:BB:C2K:PPARameter:TCHannel:FLENgth</code>	111
<code>[:SOURce<hw>]:BB:C2K:PPARameter:TCHannel:SCHannel:COUNt</code>	112

`[:SOURce<hw>]:BB:C2K:PPARameter:CRESt <Crest>`

This command selects the desired range for the crest factor of the test scenario. The crest factor of the signal is kept in the desired range by automatically setting appropriate Walsh codes and timing offsets.

The setting takes effect only after execution of command `[:SOURce<hw>]:BB:C2K:PPARameter:EXECute`.

The setting of command `[:SOURce<hw>]:BB:C2K:BSTation<st>:CGRoup<di0>:COFFset<ch>:WCODe` is adjusted according to the selection.

Parameters:

<Crest>

MINimum | AVERage | WORSt

MINimum

The crest factor is minimized. The Walsh codes are spaced as closely as possible.

AVERage

An average crest factor is set. The Walsh codes are distributed uniformly over the code domain.

WORSt

The crest factor is set to an unfavorable value (i.e. maximum). The Walsh codes are as wildly spaced as possible.

*RST: MINimum

Example:

`BB:C2K:PPAR:CRESt WORSt`

Sets the crest factor to an unfavorable value.

Manual operation: See "[Crest Factor - Predefined Settings](#)" on page 46

`[:SOURce<hw>]:BB:C2K:PPARameter:EXECute`

This command presets the channel table of base station 1 with the parameters defined by the `PPARameter` commands.

Example:

`BB:C2K:PPAR:EXEC`

configures the signal sequence as defined by the `:BB:C2K:PPARameter` commands.

Usage:

Event

Manual operation: See "[Accept - Predefined Settings](#)" on page 46

`[:SOURce<hw>]:BB:C2K:PPARameter:PCHannel[:STATe] <State>`

The command activates/deactivates the paging channel.

The setting takes effect only after execution of command `[:SOURce<hw>] :BB:C2K:PPARameter:EXECute`.

Parameters:

<State> 0 | 1 | OFF | ON
*RST: ON

Example:

BB:C2K:PPAR:PCH ON
activates F-PCH.

Manual operation: See ["Use Paging Channel \(F-PCH\) - Predefined Settings"](#) on page 45

[:SOURce<hw>] :BB:C2K:PPARameter:PIChannel[:STATe] <State>

The command activates/deactivates the pilot channel.

The setting takes effect only after execution of command `[:SOURce<hw>] :BB:C2K:PPARameter:EXECute`.

Parameters:

<State> 0 | 1 | OFF | ON
*RST: ON

Example:

BB:C2K:PPAR:PICH ON
activates F-PICH.

Manual operation: See ["Use Pilot \(F-PICH\) - Predefined Settings"](#) on page 45

[:SOURce<hw>] :BB:C2K:PPARameter:RCONfiguration <RConfiguration>

Selects the radio configuration for the traffic channel.

The setting takes effect only after execution of command `[:SOURce<hw>] :BB:C2K:PPARameter:EXECute`.

Parameters:

<RConfiguration> 1 | 2 | 3 | 4 | 5
*RST: 1

Example:

BB:C2K:PPAR:RCON 1
selects radio configuration 1.

Manual operation: See ["Radio Configuration - Predefined Settings"](#) on page 44

[:SOURce<hw>] :BB:C2K:PPARameter:SCHannel[:STATe] <State>

Activates/deactivates the F-SYNC.

The setting takes effect only after execution of command `[:SOURce<hw>] :BB:C2K:PPARameter:EXECute`.

Parameters:

<State> 0 | 1 | OFF | ON
 *RST: 1

Example:

BB:C2K:PPAR:SCH ON
 activates the F-SYNC.

Manual operation: See ["Use Sync \(F-Sync\) - Predefined Settings"](#) on page 45

[:SOURce<hw>]:BB:C2K:PPARameter:TCHannel:COUNT <Count>

This command sets the number of activated traffic channels.

The setting takes effect only after execution of command [\[:SOURce<hw>\]:BB:C2K:PPARameter:EXECute](#).

Parameters:

<Count> integer
 Range: 0 to 8
 *RST: 1

Example:

BB:C2K:PPAR:TCH:COUN 2
 the predefined signal contains 2 traffic channels.

Manual operation: See ["Number of Traffic Channels - Predefined Settings"](#) on page 45

[:SOURce<hw>]:BB:C2K:PPARameter:TCHannel:DATA:RATE <Rate>

This command sets the data rate of F-FCH and F-SCH. The set value is specific for the selected radio configuration.

The setting takes effect only after execution of command [\[:SOURce<hw>\]:BB:C2K:PPARameter:EXECute](#). It is specific for the selected radio configuration.

The value range depends on the frame length. If the frame length is changed so that the set data rate becomes invalid, the next permissible value is automatically set.

The data rate affects the Walsh code (spreading factor) that are possible within a channel. If a data rate is changed so that the selected Walsh code becomes invalid, the next permissible value is automatically set.

Parameters:

<Rate> DR1K2 | DR1K3 | DR1K5 | DR1K8 | DR2K4 | DR2K7 | DR3K6 |
 DR4K8 | DR7K2 | DR9K6 | DR14K4 | DR19K2 | DR28K8 |
 DR38K4 | DR57K6 | DR76K8 | DR115K2 | DR153K6 |
 DR230K4 | DR259K2 | DR307K2 | DR460K8 | DR518K4 |
 DR614K4 | DR1036K8 | NUSed
 *RST: DR1K2

Example:

BB:C2K:PPAR:TCH:DATA:RATE D240K
 sets the data rate of F-FCH and F-SCH to 240 kbps.

Manual operation: See ["Data Rate - Predefined Settings"](#) on page 46

[:SOURce<hw>]:BB:C2K:PPARameter:TCHannel:DCCHannel[:STATe] <State>

Activates/deactivates the dedicated control channel. F-DCCH cannot be selected for RC1 and RC2.

The setting takes effect only after execution of command [:SOURce<hw>] :BB:C2K:PPARameter:EXECute. It is specific for the selected radio configuration.

Parameters:

<State> 0 | 1 | OFF | ON
 *RST: 1

Example: BB:C2K:PPAR:TCH:DCCH ON
 Activates F-DCCH.

Manual operation: See "Use Dedicated Control (F-DCCH) - Predefined Settings" on page 45

[:SOURce<hw>]:BB:C2K:PPARameter:TCHannel:FCHannel[:STATe] <State>

Activates/deactivates the fundamental channel.

The setting takes effect only after execution of command [:SOURce<hw>] :BB:C2K:PPARameter:EXECute. It is specific for the selected radio configuration.

Parameters:

<State> 0 | 1 | OFF | ON
 *RST: 1

Example: BB:C2K:PPAR:TCH:FCH ON
 activates F-FCH.

Manual operation: See "Use Fundamental (F-FCH) - Predefined Settings" on page 45

[:SOURce<hw>]:BB:C2K:PPARameter:TCHannel:FLENgth <FLength>

The command activates/deactivates the fundamental channel. The set value is specific for the selected radio configuration.

The setting takes effect only after execution of command [:SOURce<hw>] :BB:C2K:PPARameter:EXECute. It is specific for the selected radio configuration.

The frame length affects the data rates that are possible within a channel. Changing the frame length can lead to a change of data rate and this in turn can bring about a change of Walsh code.

Parameters:

<FLength> 20 | 40 | 80
 *RST: 20 ms

Example: BB:C2K:PPAR:TCH:FLEN 20 ms
 Sets the frame length of the code channels to 20 ms.

Manual operation: See "Frame Length - Predefined Settings" on page 46

[:SOURce<hw>]:BB:C2K:PPARAmeter:TCHannel:SCHannel:COUNT <Count>

Sets the number of supplemental channels. The maximum number of supplemental channels depends on the selected radio configuration.

The setting takes effect only after execution of command `[:SOURce<hw>] :BB:C2K:PPARAmeter:EXECute`. It is specific for the selected radio configuration.

Parameters:

<Count> integer
 Range: 0 to 7
 *RST: 1

Example: `BB:C2K:PPAR:TCH:SCH:COUN 2`
 selects two F-SCHs.

Manual operation: See "Number of Supplemental (F-SCH) - Predefined Settings" on page 45

5.7 Base Stations Settings

The `SOURce:BB:C2K:BSTation` system contains commands for setting base stations.

The commands of this system only take effect if the CDMA2000 standard is activated, the DOWN transmission direction is selected and the particular base station is enabled:

- `SOURce:BB:C2K:STATe ON`
- `SOURce:BB:C2K:LINK DOWN`
- `SOURce:BB:C2K:BSTation2:STATe ON`

Suffixes



The channel table for the base station is configured from 14 special channels and up to eight traffic channels. Each traffic channel consists of four to eight code channels. The type and number of code channels depends on the radio configuration chosen for the traffic channel.

The individual channels are selected in SCPI via the suffixes to keywords `CGRoup` and `COFFset`.

The special channels have the suffix 0 to `CGRoup` and 1 to 14 to `COFFset` corresponding to the channel index 0 to 1 to 0 to 14 in the channel table.

The code channels of a traffic channel are addressed by means of suffixes 1 to 8 for the traffic channel and 1 to 8 to `COFFset` for the sub channels of the selected traffic channel. Thus `CGRoup2:COFFset1` is the code channel F-FCH of the traffic channel 2 and equates to the channel index 2 to 1 in the channel table.

Table 5-1: Structure of the traffic channel for different radio configurations.

	Radio Configuration 1, 2	Radio Configuration 3, 4, 5
1-1 (CGROUP1:COFFSET1)	F-FCH	F-FCH
1-2 (CGROUP1:COFFSET2)	F-SCH1	F-SCH1
1-3 (CGROUP1:COFFSET3)	F-SCH2	F-SCH2
1-4 (CGROUP1:COFFSET4)	F-SCH3	F-DCCH
1-5 (CGROUP1:COFFSET5)	F-SCH4	-
1-6 (CGROUP1:COFFSET6)	F-SCH5	-
1-7 (CGROUP1:COFFSET7)	F-SCH6	-
1-8 (CGROUP1:COFFSET8)	F-SCH7	-

Regardless of the radio configuration, in all traffic channels the COFFSET1 corresponds to the F-FCH, and the COFFSET2 and COFFSET3 correspond to the F-SCH1 and F-SCH2, respectively. In radio configurations 1 and 2 the COFFSET4 corresponds to the F-SCH3, and in radio configurations 3, 4, 5 to the F-DCCH. COFFSET5, COFFSET6, COFFSET7 and COFFSET8 exist only in radio configurations 1 and 2, where they correspond to the F-SCH4 to F-SCH7.



For the code channels of a traffic channels, the settings of the channel table parameters are specific for the selected radio configuration. I.e. a complete set of settings exists for each of the five possible radio configurations.

See also "Common suffixes" on page 85.

- [SOURce<hw>]:BB:C2K:BSTation:PRESet..... 114
- [SOURce<hw>]:BB:C2K:BSTation:SYNC:CNUMBER..... 115
- [SOURce<hw>]:BB:C2K:BSTation:SYNC:LCSTATE..... 115
- [SOURce<hw>]:BB:C2K:BSTation:SYNC:MPREV..... 115
- [SOURce<hw>]:BB:C2K:BSTation:SYNC:NID..... 116
- [SOURce<hw>]:BB:C2K:BSTation:SYNC:PREV..... 116
- [SOURce<hw>]:BB:C2K:BSTation:SYNC:SID..... 116
- [SOURce<hw>]:BB:C2K:BSTation:SYNC:STIME..... 117
- [SOURce<hw>]:BB:C2K:BSTation<st>:CGROUP<di0>:COFFSET<ch>:CCODING:
BINTerleaver?..... 117
- [SOURce<hw>]:BB:C2K:BSTation<st>:CGROUP<di0>:COFFSET<ch>:CCODING:BITFrame?. 118
- [SOURce<hw>]:BB:C2K:BSTation<st>:CGROUP<di0>:COFFSET<ch>:CCODING:CRC?..... 118
- [SOURce<hw>]:BB:C2K:BSTation<st>:CGROUP<di0>:COFFSET<ch>:CCODING:DATA:
RATE?..... 119
- [SOURce<hw>]:BB:C2K:BSTation<st>:CGROUP<di0>:COFFSET<ch>:CCODING:MODE..... 119
- [SOURce<hw>]:BB:C2K:BSTation<st>:CGROUP<di0>:COFFSET<ch>:CCODING:
SPUNcture?..... 120
- [SOURce<hw>]:BB:C2K:BSTation<st>:CGROUP<di0>:COFFSET<ch>:CCODING:
SREPetition?..... 120
- [SOURce<hw>]:BB:C2K:BSTation<st>:CGROUP<di0>:COFFSET<ch>:CCODING:TYPE..... 121
- [SOURce<hw>]:BB:C2K:BSTation<st>:CGROUP<di0>:COFFSET<ch>:DATA..... 121

[SOURce<hw>]:BB:C2K:BSTation<st>:CGROUP<di0>:COFFset<ch>:DATA:DSElect.....	122
[SOURce<hw>]:BB:C2K:BSTation<st>:CGROUP<di0>:COFFset<ch>:DATA:PATtern.....	123
[SOURce<hw>]:BB:C2K:BSTation<st>:CGROUP<di0>:COFFset<ch>:DATA:RATE.....	123
[SOURce<hw>]:BB:C2K:BSTation<st>:CGROUP<di0>:COFFset<ch>:DERRor:BIT:RATE.....	124
[SOURce<hw>]:BB:C2K:BSTation<st>:CGROUP<di0>:COFFset<ch>:DERRor:BIT:STATe...	124
[SOURce<hw>]:BB:C2K:BSTation<st>:CGROUP<di0>:COFFset<ch>:DERRor:BLOCK: RATE.....	124
[SOURce<hw>]:BB:C2K:BSTation<st>:CGROUP<di0>:COFFset<ch>:DERRor:BLOCK: STATe.....	125
[SOURce<hw>]:BB:C2K:BSTation<st>:CGROUP<di0>:COFFset<ch>:FLEngth.....	125
[SOURce<hw>]:BB:C2K:BSTation<st>:CGROUP<di0>:COFFset<ch>:LCMask.....	126
[SOURce<hw>]:BB:C2K:BSTation<st>:CGROUP<di0>:COFFset<ch>:POWER.....	126
[SOURce<hw>]:BB:C2K:BSTation<st>:CGROUP<di0>:COFFset<ch>:QWCode:STATe.....	127
[SOURce<hw>]:BB:C2K:BSTation<st>:CGROUP<di0>:COFFset<ch>:REALtime:STATe.....	127
[SOURce<hw>]:BB:C2K:BSTation<st>:CGROUP<di0>:COFFset<ch>:STATe.....	127
[SOURce<hw>]:BB:C2K:BSTation<st>:CGROUP<di0>:COFFset<ch>:TPC:DATA.....	128
[SOURce<hw>]:BB:C2K:BSTation<st>:CGROUP<di0>:COFFset<ch>:TPC:DATA:DSElect..	128
[SOURce<hw>]:BB:C2K:BSTation<st>:CGROUP<di0>:COFFset<ch>:TPC:DATA:PATtern..	129
[SOURce<hw>]:BB:C2K:BSTation<st>:CGROUP<di0>:COFFset<ch>:TPC:MISuse.....	130
[SOURce<hw>]:BB:C2K:BSTation<st>:CGROUP<di0>:COFFset<ch>:TPC:PSTep.....	130
[SOURce<hw>]:BB:C2K:BSTation<st>:CGROUP<di0>:COFFset<ch>:TPC:READ.....	131
[SOURce<hw>]:BB:C2K:BSTation<st>:CGROUP<di0>:COFFset<ch>:TYPE?.....	132
[SOURce<hw>]:BB:C2K:BSTation<st>:CGROUP<di0>:COFFset<ch>:WCODE.....	132
[SOURce<hw>]:BB:C2K:BSTation<st>:CGROUP<di0>:COFFset<ch>:WLEngth?.....	133
[SOURce<hw>]:BB:C2K:BSTation<st>:CGROUP<di0>:RCONfiguration.....	133
[SOURce<hw>]:BB:C2K:BSTation<st>:DCONflict:MODE.....	133
[SOURce<hw>]:BB:C2K:BSTation<st>:DCONflict:RESolve.....	134
[SOURce<hw>]:BB:C2K:BSTation<st>:DCONflict[:STATe]?.....	134
[SOURce<hw>]:BB:C2K:BSTation<st>:PDCHannel:PINTerval.....	134
[SOURce<hw>]:BB:C2K:BSTation<st>:PDCHannel:PSETup.....	135
[SOURce<hw>]:BB:C2K:BSTation<st>:PDCHannel:SUBPacket<di>:ID.....	135
[SOURce<hw>]:BB:C2K:BSTation<st>:PDCHannel:SUBPacket<di>:PARAmeters.....	136
[SOURce<hw>]:BB:C2K:BSTation<st>:PDCHannel:SUBPacket<di>:STATe.....	140
[SOURce<hw>]:BB:C2K:BSTation<st>:PDCHannel:SUBPacket<di>:TOFFset.....	141
[SOURce<hw>]:BB:C2K:BSTation<st>:PDCHannel:SUBPacket<di>:WCODes?.....	141
[SOURce<hw>]:BB:C2K:BSTation<st>:PDCHannel:WINDex.....	141
[SOURce<hw>]:BB:C2K:BSTation<st>:PNOFFset.....	142
[SOURce<hw>]:BB:C2K:BSTation<st>:QWSet.....	142
[SOURce<hw>]:BB:C2K:BSTation<st>:STATe.....	142
[SOURce<hw>]:BB:C2K:BSTation<st>:TDElay.....	143
[SOURce<hw>]:BB:C2K:BSTation<st>:TDIVersity.....	143
[SOURce<hw>]:BB:C2K:BSTation<st>:TDIVersity:MODE.....	143

[SOURce<hw>]:BB:C2K:BSTation:PRESet

A standardized default for all the base stations (*RST values specified for the commands).

See "Reset All Base Stations" on page 27 for an overview.

Example: SOURce1:BB:C2K:BSTation:PRESet

Usage: Event

Manual operation: See ["Reset All Base Stations"](#) on page 27

[[:SOURce<hw>]:BB:C2K:BSTation:SYNC:CNUMber <CNumber>

Sets the CDMA Channel Number which corresponds to the RF.

Parameters:

<CNumber> integer
 Range: 0 to 2047
 *RST: 387

Example: BB:C2K:BST:SYNC:CNUM 400
 sets the channel number

Manual operation: See ["CDMA Channel Number - More Params BS"](#) on page 69

[[:SOURce<hw>]:BB:C2K:BSTation:SYNC:LCState <LcState>

(available for R&S SMBV instruments only)

Defines the long code state in hexadecimal format.

Parameters:

<LcState> 42 bit
 Range: 0 to 3FFFFFFFFF
 *RST: 0

Example: BB:C2K:BST:SYNC:LCST #H0001F3A002E1
 sets the Long Code state parameter.

Manual operation: See ["LC State \(hex\) - More Params BS"](#) on page 69

[[:SOURce<hw>]:BB:C2K:BSTation:SYNC:MPRev <MPrev>

Sets the Minimum Protocol Revision Level.

The base station sets this field to prevent mobile stations which cannot be supported by the base station from accessing the CDMA system.

Parameters:

<MPrev> 2 | 8
 Range: 2 to 8
 *RST: 2

Example: BB:C2K:BST:SYNC:MPR 3
 Sets the MIN_P_REV parameter

Manual operation: See ["MIN_P_REV - More Params BS"](#) on page 70

[:SOURCE<hw>]:BB:C2K:BSTation:SYNC:NID <Nid>

Sets the Network Identification.

The NID serves as a sub-identifier of a CDMA system as defined by the owner of the SID.

Parameters:

<Nid> integer
 Range: 0 to 65535
 *RST: 1

Example: BB:C2K:BST:SYNC:NID 5
 sets the network identification parameter

Manual operation: See "[NID - More Params BS](#)" on page 70

[:SOURCE<hw>]:BB:C2K:BSTation:SYNC:PREV <Prev>

Sets the Protocol Revision Level, i.e. specifies the CDMA2000 system release number.

The table below gives the cross-reference between the P_REV values and the CDMA2000 Releases.

P_REV	CDMA2000 Release
1	Korean PCS(Band Class4), USPCS(Band Class1)
2	IS-95
3	TBS74
4	IS-95A
5	IS-95B
6	IS2000 Release 0
7	IS2000 Release A
8	IS2000 Release B

Parameters:

<Prev> integer
 Range: 1 to 8
 *RST: 6

Example: BB:C2K:BST:SYNC:PREV 4
 sets the P_REV parameter

Manual operation: See "[P_REV - More Params BS](#)" on page 69

[:SOURCE<hw>]:BB:C2K:BSTation:SYNC:SID <Sid>

Displays the System Identification.

The base station sets the system identification number.

Parameters:

<Sid> integer
 Range: 0 to 32767
 *RST: 10

Example: BB:C2K:BST:SYNC:SID 10
 sets the system identification parameter

Manual operation: See "[SID - More Params BS](#)" on page 70

[:SOURce<hw>]:BB:C2K:BSTation:SYNC:STIME <SystTime>

(available for R&S SMBV instruments only)

Displays the system time.

Parameters:

<SystTime> integer
 Range: 0 to 68719476735
 *RST: 0

Example: BB:C2K:BST:SYNC:STIM 4
 sets the system time.

Manual operation: See "[System Time - More Params BS](#)" on page 69

**[:SOURce<hw>]:BB:C2K:BSTation<st>:CGRoup<di0>:COFFset<ch>:CCODing:
 BINTerleaver?**

The command queries the number of symbols per block which are processed by the interleaver. This value is only available for channel coding modes "Complete" and "Without Interleaving"

(SOURce:BB:C2K:BST<n>:CGRoup<n>:COFFset<n>:CCODing:MODE COMP | NOIN).

For the traffic channels, this value is specific for the selected radio configuration.

Return values:

<BInterleaver> 48 | 96 | 128 | 144 | 192 | 288 | 384 | 576 | 768 | 1152 | 1536 |
 2304 | 3072 | 4608 | 6144 | 9216 | 12288 | 18432 | 36864 |
 NONE

Example: BB:C2K:BST:CGR3:COFF1:CCOD:MODE COMP
 selects channel coding mode "Complete" for F-FCH of the third traffic channel.

BB:C2K:BST:CGR3:COFF1:CCOD:BINT?

queries the number of symbols per block which are processed by the interleaver.

Response: 384

384 symbols per block are processed.

Usage: Query only

Manual operation: See "[Block Interleaver - More Params BS](#)" on page 68

[:SOURce<hw>]:BB:C2K:BSTation<st>:CGRoup<di0>:COFFset<ch>:CCODing:BITFrame?

Queries the number of input bits per frame for the channel coder. This value is only available for channel coding modes "Complete" and "Without Interleaving" (SOURce:BB:C2K:BST<n>:CGRoup<n>:COFFset<n>:CCODing:MODE COMP | NOIN).

For the traffic channels, this value is specific for the selected radio configuration.

Return values:

<BitFrame> integer
 Range: 16 to 20712
 *RST: 16

Example:

BB:C2K:BST:CGR3:COFF1:CCOD:MODE COMP
 selects channel coding mode "Complete" for F-FCH of the third traffic channel.
 BB:C2K:BST:CGR3:COFF1:CCOD:BITF?
 queries the number of input bits per frame.
 Response: 16
 16 bits per frame.

Usage: Query only

Manual operation: See "[Source Bits / Frame - More Params BS](#)" on page 67

[:SOURce<hw>]:BB:C2K:BSTation<st>:CGRoup<di0>:COFFset<ch>:CCODing:CRC?

Queries the CRC (cyclic redundancy code) type (length). This value is only available for channel coding modes "Complete" and "Without Interleaving" (SOURce:BB:C2K:BST<n>:CGRoup<n>:COFFset<n>:CCODing:MODE COMP | NOIN).

For the traffic channels, this value is specific for the selected radio configuration.

Return values:

<Crc> integer
 Range: 0 to 16
 *RST: 0

Example:

BB:C2K:BST:CGR1:COFF1:CCOD:MODE COMP
 selects channel coding mode "Complete" for F-FCH of the first traffic channel.
 BB:C2K:BST:CGR1:COFF1:CCOD:CRC?
 queries the CRC type.
 Response: 6
 CRC type 6 is used.

Usage: Query only

[:SOURce<hw>]:BB:C2K:BSTation<st>:CGRoup<di0>:COFFset<ch>:CCODing:DATA:RATE?

The command queries the effective data rate in Hz. This value is only available for channel coding modes "Off" and "Interleaving Only"

(SOURce:BB:C2K:BST<n>:CGRoup<n>:COFFset<n>:CCODing:MODE OFF | OINT).

When channel coding is switched off, the effective data rate differs from the data rate set in the channel table. The data are read out with the effective rate.

For the traffic channels, this value is specific for the selected radio configuration.

Return values:

<Rate> float

Example:

BB:C2K:BST:CGR3:COFF1:CCOD:MODE OINT
selects channel coding mode "Interleaving Only" for F-FCH of the third traffic channel.

BB:C2K:BST:CGR3:COFF1:CCOD:DATA:RATE?
queries the effective data rate.

Response: 19200
the effective data is 19.2 kbps.

Usage: Query only

Manual operation: See ["Effective Data Rate - More Params BS"](#) on page 67

[:SOURce<hw>]:BB:C2K:BSTation<st>:CGRoup<di0>:COFFset<ch>:CCODing:MODE <Mode>

Selects channel coding mode. For the traffic channels, this value is specific for the selected radio configuration.

Parameters:

<Mode> OFF | COMPLETE | NOINTERleaving | OINTERleaving

OFF

Channel coding is deactivated.

COMPLETE

The complete channel coding is performed. The channel coding procedure can slightly vary depending on channel type, frame length and data rate.

OINTERleaving

Except for the block interleaver, the whole channel coding procedure is carried out. In this mode, the frame structure and the convolutional coder of a receiver can be tested.

NOINTERleaving

In this mode, only block interleaver is used for coding. This allows the deinterleaver in the receiver to be tested independently of the remaining (de-)coding process.

*RST: COMPLETE

Example: BB:C2K:BST:CGR3:COFF1:CCOD:MODE OFF
Deactivates channel coding for F-FCH of the third traffic channel.

Manual operation: See "[Channel Coding Mode - More Params BS](#)" on page 66

[:SOURCE<hw>]:BB:C2K:BSTation<st>:CGRoup<di0>:COFFset<ch>:CCODing:SPUNcture?

The command queries the symbol puncture rate. This value is only available for channel coding modes "Complete" and "Without Interleaving"

(SOURCE:BB:C2K:BST<n>:CGRoup<n>:COFFset<n>:CCODing:MODE COMP | NOIN).

For the traffic channels, this value is specific for the selected radio configuration.

Return values:

<SPuncture> 8OF24 | 1OF5 | 1OF9 | 4OF12 | 2OF18 | 2OF6 | T2OF18 | T4OF12 | NONE

xOFy

a symbol puncture rate of x out of y is used

TxOFy

a symbol puncture rate of x out of y Turbo is used

Example: BB:C2K:BST:CGR3:COFF1:CCOD:MODE COMP
selects channel coding mode "Complete" for F-FCH of the third traffic channel.

BB:C2K:BST:CGR3:COFF1:CCOD:SPUN?

queries the symbol puncture rate.

Response: 8OF24

a symbol puncture rate of 8 out of 24 is used.

Usage: Query only

Manual operation: See "[Symbol Puncture - More Params BS](#)" on page 68

[:SOURCE<hw>]:BB:C2K:BSTation<st>:CGRoup<di0>:COFFset<ch>:CCODing:SREPetition?

Queries symbol repetition rate. This value is only available for channel coding modes "Complete" and "Without Interleaving"

(SOURCE:BB:C2K:BST<n>:CGRoup<n>:COFFset<n>:CCODing:MODE COMP | NOIN).

For the traffic channels, this value is specific for the selected radio configuration.

Return values:

<SRepetition> integer
Range: 1 to 16
*RST: 0

- Example:** BB:C2K:BST:CGR3:COFF1:CCOD:MODE COMP
selects channel coding mode "Complete" for F-FCH of the third traffic channel.
BB:C2K:BST:CGR3:COFF1:CCOD:SREP?
queries symbol repetition rate.
Response: 8
a symbol repetition rate of 8 is used.
- Usage:** Query only
- Manual operation:** See ["Symbol Repetition - More Params BS"](#) on page 68

[:SOURCE<hw>]:BB:C2K:BSTation<st>:CGRoup<di0>:COFFset<ch>:CCODing:TYPE <Type>

The command sets the channel coding type.

This value is only available for channel coding modes "Complete" and "Without Interleaving" (SOURCE:BB:C2K:BST<n>:CGRoup<n>:COFFset<n>:CCODing:MODE COMP | NOIN). For the traffic channels, this value is specific for the selected radio configuration.

Parameters:

<Type> CON2 | CON3 | CON4 | CON6 | TUR2 | TUR3 | TUR4 | TUR5 | OFF | DEFault

NONE
No error protection

TURx
Turbo Coder of rate 1/x in accordance with the CDMA specifications.

CONx
Convolution Coder of rate 1/x with generator polynomials defined by CDMA.

*RST: Channel-specific

- Example:** BB:C2K:BST:CGR3:COFF2:CCOD:MODE COMP
selects channel coding mode "Complete" for F-SCH1 of the third traffic channel.
BB:C2K:BST:CGR3:COFF2:CCOD:TYPE TURB4
selects turbo coder with a rate of 1/4 for F-SCH1 of the third traffic channel.

Manual operation: See ["Channel Coder Type - More Params BS"](#) on page 67

[:SOURCE<hw>]:BB:C2K:BSTation<st>:CGRoup<di0>:COFFset<ch>:DATA <Data>

The command selects the data source for the specified channel.

For the traffic channels, this value is specific for the selected radio configuration.

The data source for the power control bits is selected with the command :BB:C2K:BST<n>:CGRoup<n>:COFFset<n>:TPC:DATA.

Parameters:

<Data> ZERO | ONE | PATTErn | PN9 | PN11 | PN15 | PN16 | PN20 | PN21 | PN23 | DLISt

PNxx
The pseudo-random sequence generator is used as the data source. Different random sequence lengths can be selected.

DLISt
A data list is used. The data list is selected with the command :BB:C2K:BST<n>:CGRoup<n>:COFFset<n>:DATA:DSEL.

ZERO | ONE
Internal 0 and 1 data is used.

PATTErn
Internal data is used. The bit pattern for the data is defined by the command :BB:C2K:BST:CGRoup:COFFset:DATA:PATT.

*RST: F-PICH; F-TDPICH; F-APICH; F-ATDPICH: ALL0;
all other channels: PN9

Example:

```
BB:C2K:BST2:CGR3:COFF1:DATA PATT
```

Selects as the data source for the F-FCH of the third traffic channel of base station 2, the bit pattern defined with the following command:

```
BB:C2K:BST2:CGR3:COFF1:DATA:PATT #H3F,8
```

Defines the bit pattern.

Manual operation: See "[Data List Management](#)" on page 24

[:SOURce<hw>]:BB:C2K:BSTation<st>:CGRoup<di0>:COFFset<ch>:DATA:DSELEct <DSelect>

The command selects the data list for the DLISt data source selection.

The lists are stored as files with the fixed file extensions *.dm_iqd in a directory of the user's choice. The directory applicable to the following commands is defined with the command MEMORy:CDIR. To access the files in this directory, you only have to give the file name, without the path and the file extension.

For the traffic channels, this value is specific for the selected radio configuration.

Parameters:

<DSelect> string

Example: BB:C2K:BST2:CGR3:COFF1:DATA DLIS
selects the Data Lists data source for the F-FCH of the third traffic channel of basestation2.
MEM:CDIR "<root>Lists"
selects the directory for the data lists.
BB:C2K:BST2:CGR3:COFF1:DATA:DLIS "cdma_list1"
selects file "cdma_list1" as the data source. This file must be in specified directory and it must have the file extension *.dm_iqd.

Manual operation: See "[Data List Management](#)" on page 24

[:SOURCE<hw>]:BB:C2K:BSTation<st>:CGRoup<di0>:COFFset<ch>:DATA:PATTern <Pattern>

Sets the bit pattern for the PATTern selection. The first parameter determines the bit pattern (choice of hexadecimal, octal or binary notation), the second specifies the number of bits to use. The maximum length is 64 bits.

For the traffic channels, this value is specific for the selected radio configuration.

Parameters:

<Pattern> 64 bits

Example: BB:C2K:BST2:CGR3:COFF1:DATA:PATT #H800FE038,30
defines the bit pattern.

Manual operation: See "[Data](#)" on page 60

[:SOURCE<hw>]:BB:C2K:BSTation<st>:CGRoup<di0>:COFFset<ch>:DATA:RATE <Rate>

The command sets the data rate for the specified channel. The value range depends on the channel type, the selected radio configuration and the frame length. Parameter NUSed is returned for channel 0-1 to 0-4.

For the traffic channels, this value is specific for the selected radio configuration.

The value range depends on the frame length. If the frame length is changed so that the set data rate becomes invalid, the next permissible value is automatically set.

The data rate affects the Walsh code (spreading factor) that are possible within a channel. If a data rate is changed so that the selected Walsh code becomes invalid, the next permissible value is automatically set.

Parameters:

<Rate> DR1K2 | DR1K3 | DR1K5 | DR1K8 | DR2K4 | DR2K7 | DR3K6 | DR4K8 | DR7K2 | DR9K6 | DR14K4 | DR19K2 | DR28K8 | DR38K4 | DR57K6 | DR76K8 | DR115K2 | DR153K6 | DR230K4 | DR307K2 | NUSed

*RST: Channel-specific

Example: BB:C2K:BST2:CGR3:COFF1:DATA:RATE DR4K8
sets a data rate of 4.8 kbps for F-FCH of the third traffic channel of base station 2.

Manual operation: See ["Data Rate"](#) on page 59

**[:SOURCE<hw>]:BB:C2K:BSTation<st>:CGROUP<di0>:COFFset<ch>:DERRor:
BIT:RATE <Rate>**

(not available in R&S SMBV)

Sets the bit error rate.

Parameters:

<Rate> float
Range: 1E-7 to 0.1
Increment: 1E-7
*RST: 1E-3

Example: see [\[:SOURCE<hw>\]:BB:C2K:BSTation<st>:
CGROUP<di0>:COFFset<ch>:DERRor:BLOCK:STATE](#)
on page 125

Manual operation: See ["Bit Error Rate - More Params BS"](#) on page 71

**[:SOURCE<hw>]:BB:C2K:BSTation<st>:CGROUP<di0>:COFFset<ch>:DERRor:
BIT:STATE <State>**

(not available in R&S SMBV)

Activates bit error generation.

Parameters:

<State> 0 | 1 | OFF | ON

Example: see [\[:SOURCE<hw>\]:BB:C2K:BSTation<st>:
CGROUP<di0>:COFFset<ch>:DERRor:BLOCK:STATE](#)
on page 125

Manual operation: See ["Bit Error State - More Params BS"](#) on page 71

**[:SOURCE<hw>]:BB:C2K:BSTation<st>:CGROUP<di0>:COFFset<ch>:DERRor:
BLOCK:RATE <Rate>**

(not available in R&S SMBV)

Sets the block error rate.

Block error generation is only possible when channel coding is activated. For the traffic channels, this value is specific for the selected radio configuration.

Parameters:

<Rate> float
 Range: 1E-4 to 0.1
 Increment: 1E-4
 *RST: 0.1

Example:

see `[:SOURce<hw>] :BB:C2K:BSTation<st> :
 CGRoup<di0> :COFFset<ch> :DERRor:BLOCK:STATE`
 on page 125

Manual operation: See ["Block Error Rate - More Params BS"](#) on page 71

`[:SOURce<hw>] :BB:C2K:BSTation<st> :CGRoup<di0> :COFFset<ch> :DERRor:
 BLOCK:STATE <State>`

(not available in R&S SMBV)

Activates or deactivates block error generation.

Parameters:

<State> 0 | 1 | OFF | ON

Example:

```
BB:C2K:BST:CGR1:COFF3:REAL:STAT ON
// activates the generation of F-SCH2
// of the first traffic channel of BS1
BB:C2K:BST:CGR1:COFF3:CCOD:MODE COMP
// activates complete channel coding
BB:C2K:BST:CGR1:COFF3:DERR:BLOC:RATE 1E-2
// sets the block error rate
BB:C2K:BST:CGR1:COFF3:DERR:BLOC:STAT ON
// activates block error generation
BB:C2K:BST:CGR1:COFF3:DERR:BIT:RATE 1E-4
// sets a bit error rate
BB:C2K:BST:CGR1:COFF3:DERR:BIT:STAT ON
// activates bit error generation
```

Manual operation: See ["Block Error State - More Params BS"](#) on page 71

`[:SOURce<hw>] :BB:C2K:BSTation<st> :CGRoup<di0> :COFFset<ch> :FLENgth
 <FLength>`

The command sets the frame length of the selected channel. The value range is channel specific.

For the traffic channels, this value is specific for the selected radio configuration.

The value range of the frame length depends on the channel type and the selected radio configuration.

The frame length affects the data rates that are possible within a channel. Changing the frame length can lead to a change of data rate and this in turn can bring about a change of Walsh code.

Parameters:

<FLength> 5 | 10 | 20 | 26.6 | 40 | 80 | 160 | NUSed

26 ms

Frame length of 26.6. Also all inputs 26.6 ms and 26.7 ms are allowed.

*RST: F-SYNC: 26.6; F_BCH: 40 ms; F_CACH: 5 ms; all other channels: 20 ms

Example:

BB:C2K:BST:CGR3:COFF4:FLEN 5 ms

Sets the frame length of sub channel 3 ms to 4 ms to 5 ms.

Manual operation: See "[Frame Length- BS](#)" on page 59

[:SOURce<hw>]:BB:C2K:BSTation<st>:CGRoup<di0>:COFFset<ch>:LCMask
<LcMask>

The command sets the mask of the Long Code Generator of the base station.

For the traffic channels, this value is specific for the selected radio configuration.

The LC Mask is the same for all sub channels of a traffic channel. If the mask is modified for one of the sub channels, the new value is then automatically used by all other subchannels of this traffic channel.

Parameters:

<LcMask> integer

Range: #H0 to #H3FF FFFF FFFF

*RST: #H0

Example:

BB:C2K:BST1:CGR2:COFF1:LCM #H55

Sets the Long Code Mask to #H55.

Manual operation: See "[LC Mask \(hex\) - More Parameters BS](#)" on page 63

[:SOURce<hw>]:BB:C2K:BSTation<st>:CGRoup<di0>:COFFset<ch>:POWER
<Power>

Sets the channel power relative to the powers of the other channels. This setting also determines the starting power of the channel for Misuse Output Power Control.

With the command [:SOURce<hw>] :BB:C2K:POWER:ADJust, the power of all the activated channels is adapted so that the total power corresponds to 0 dB. This does not change the power ratio among the individual channels.

For the traffic channels, this value is specific for the selected radio configuration.

Parameters:

<Power> float

Range: -80 to depends on channel

Increment: 0.01

*RST: 0

Example: BB:C2K:BST2:CGR3:COFF4:POW -10dB
Sets the channel power of sub channel 3 to 4 of base station 2 dB to -10 dB relative to the power of the other channels.

Manual operation: See ["Power"](#) on page 60

[:SOURCE<hw>]:BB:C2K:BSTation<st>:CGRoup<di0>:COFFset<ch>:QWCode: STATE <State>

Activates/deactivates the use of the quasi orthogonal Walsh codes for the channel.

The quasi orthogonal Walsh Code set is selected for all channels of the base station with command [\[:SOURCE<hw>\]:BB:C2K:BSTation<st>:QWSet](#).

For the traffic channels, this value is specific for the selected radio configuration. It is only available for radio configuration 3 and higher.

Parameters:

<State> 0 | 1 | OFF | ON
*RST: 0

Example: BB:C2K:BST1:QWS 3
selects quasi orthogonal Walsh code set 3 for base station 1.
BB:C2K:BST1:CGR3:COFF4:QWC:STAT ON
activates the use of the quasi orthogonal Walsh code for sub channel 3-4.

Manual operation: See ["Quasi Orthogonal Walsh Code State"](#) on page 60

[:SOURCE<hw>]:BB:C2K:BSTation<st>:CGRoup<di0>:COFFset<ch>:REALtime: STATE <State>

(not available in R&S SMBV)

Activates/deactivates realtime generation of the selected channel. Realtime generation is possible for F-SYNC and the first traffic channel of base station 1.

For the traffic channel, this value is specific for the selected radio configuration.

Parameters:

<State> 0 | 1 | OFF | ON
*RST: 0

Example: BB:C2K:BST:CGR0:COFF5:REAL:STAT ON
activates realtime generation of F-SYNC of base station 1.

Manual operation: See ["Real Time - BS1"](#) on page 58

[:SOURCE<hw>]:BB:C2K:BSTation<st>:CGRoup<di0>:COFFset<ch>:STATE <State>

This command activates/deactivates the selected channel.

For the traffic channels, this value is specific for the selected radio configuration.

Parameters:

<State> 0 | 1 | OFF | ON
 *RST: OFF

Example:

BB:C2K:BST2:CGR1:COFF2:STAT OFF
 Deactivates sub channel 1 to 2 of base station 1.

Manual operation: See "[Channel State](#)" on page 61

**[:SOURce<hw>]:BB:C2K:BSTation<st>:CGRoup<di0>:COFFset<ch>:TPC:DATA
 <Data>**

Sets the data source for the power control bits of the selected F-FCH or F-DCCH.

Power control is available for sub channel types F-FCH and F-DCCH. F-DCCH is only generated for radio configurations 3, 4 and 5.

For the traffic channels, this value is specific for the selected radio configuration.

Parameters:

<Data> ZERO | ONE | PATTErn | DLISt

DLISt

A data list is used. The data list is selected with the command
 [:SOURce<hw>]:BB:C2K:BSTation<st>:CGRoup<di0>:
 COFFset<ch>:TPC:DATA:DSElect.

ZERO | ONE

Internal 0 and 1 data is used.

PATTErn

Internal data is used. The bit pattern for the data is defined by the command [:SOURce<hw>]:BB:C2K:BSTation<st>:CGRoup<di0>:COFFset<ch>:TPC:DATA:PATTErn. The maximum length is 64 bits.

*RST: ZERO

Example:

BB:C2K:BST2:CGR1:RCON 4

Selects radio configuration4 for the first traffic channel of base station 2. This setting is valid for all sub channels of this traffic channel. With RC4, the traffic channel includes an F-DCCH.

BB:C2K:BST2:CGR1:COFF4:TPC:DATA PATT

Selects as the data source for the power control bits of F-DCCH the bit pattern defined with the following command.

BB:C2K:BST2:CGR1:COFF4:TPC:DATA:PATT #HF0C20,19
 Defines the bit pattern.

Manual operation: See "[Data List Management](#)" on page 24

**[:SOURce<hw>]:BB:C2K:BSTation<st>:CGRoup<di0>:COFFset<ch>:TPC:DATA:
 DSElect <DSelect>**

The command selects the data list for the DLISt data source selection.

Power control is available for sub channel types F-DCCH and F-FCH. F-DCCH is only generated for radio configurations 3, 4 and 5.

The lists are stored as files with the fixed file extensions *.dm_iqd in a directory of the user's choice. The directory applicable to the following commands is defined with the command `MMEMORY:CDIR`. To access the files in this directory, you only have to give the file name, without the path and the file extension.

For the traffic channels, this value is specific for the selected radio configuration.

Parameters:

<DSelect> string

Example:

```
BB:C2K:BST2:CGR1:RCON 4
selects radio configuration RC4 for the first traffic channel of
base station 2. This setting is valid for all sub channels of the
traffic channel. With RC4, the traffic channel includes a F-
DCCH.
:BB:C2K:BST2:CGR1:COFF4:TPC:DATA DLIS
selects the DLIS data source.
MMEM:CDIR "<root>Lists"
selects the directory for the data lists.
BB:C2K:BST2:CGR1:COFF4:TPC:DATA:DSEL "cdma_ch4"
selects the file cdma_ch4 as the data source. This file must be
in specified directory and it must have the file extension
*.dm_iqd.
```

Manual operation: See "[Data List Management](#)" on page 24

**[:SOURCE<hw>]:BB:C2K:BSTation<st>:CGRoup<di0>:COFFset<ch>:TPC:DATA:
PATTern <Pattern>**

Sets the bit pattern for the `PATTern` selection. The maximum bit pattern length is 64 bits.

Power control is available for sub channel types F-DCCH and F-FCH. F-DCCH is only generated for radio configurations 3, 4 and 5.

For the traffic channels, this value is specific for the selected radio configuration.

Parameters:

<Pattern> 64 bits

Example:

```
BB:C2K:BST2:CGR1:RCON 4
selects radio configuration RC4 for the first traffic channel of
base station 2. This setting is valid for all sub channels of the
traffic channel. With RC4, the traffic channel includes a F-
DCCH.
BB:C2K:BST2:CGR1:COFF4:TPC:DATA:PATT #H3F,8
defines the bit pattern for the power control-bits.
```

Manual operation: See "[Data Source - Power Control - BS](#)" on page 64

[:SOURce<hw>]:BB:C2K:BSTation<st>:CGRoup<di0>:COFFset<ch>:TPC:MISuse<MisUse>

The command activates "mis-" use of the power control bits of the selected F-DCCH or F-FCH for controlling the channel powers of these channels.

Power control is available for sub channel types F-DCCH and F-FCH. F-DCCH is only generated for radio configurations 3, 4 and 5.

The bit pattern (see commands `:BB:C2K:BSTation<n>:CGRoup<n>:COFFset<n>:TPC...`) of the power control bits of each channel is used to control the channel power. A "1" leads to an increase of channel powers, a "0" to a reduction of channel powers. Channel power is limited to the range 0 dB to -80 dB. The step width of the change is defined with the command `[:SOURce<hw>]:BB:C2K:BSTation<st>:CGRoup<di0>:COFFset<ch>:TPC:PSTep`.

For the traffic channels, this value is specific for the selected radio configuration.

Parameters:

<MisUse> 0 | 1 | OFF | ON
 *RST: OFF

Example:

`BB:C2K:BST2:CGR1:RCON 4`
 selects radio configuration RC4 for the first traffic channel of base station 2. This setting is valid for all sub channels of the traffic channel. With RC4, the traffic channel includes a F-DCCH.

`BB:C2K:BST2:CGR1:COFF4:TPC:MIS ON`
 activates regulation of channel power for DCCH of the first traffic channel of base station 2 via the power control bit pattern.

`BB:C2K:BST2:CGR1:COFF4:TPC:PST 1 dB`
 sets the step width for the change of channel powers to 1 dB.

Manual operation: See "[Misuse for Output Power Control - BS](#)" on page 65

[:SOURce<hw>]:BB:C2K:BSTation<st>:CGRoup<di0>:COFFset<ch>:TPC:PSTep<PStep>

The command defines the step width for the change of channel powers in the case of "mis-" use of the power control bits.

Power control is available for sub channel types F-DCCH and F-FCH. F-DCCH is only generated for radio configurations 3, 4 and 5.

For the traffic channels, this value is specific for the selected radio configuration.

Parameters:

<PStep> float
 Range: -10 dB to 10 dB
 Increment: 0.01 dB
 *RST: 0 dB

Example: `BB:C2K:BST2:CGR1:RCON 4`
 selects radio configuration RC4 for the first traffic channel of base station 2. This setting is valid for all sub channels of the traffic channel. With RC4, the traffic channel includes a F-DCCH.

`BB:C2K:BST2:CGR1:COFF4:TPC:PST 1 dB`
 sets the step width for the change of channel powers to 1 dB.

Manual operation: See "[Power Step \(DPCCH\) - BS](#)" on page 66

[:SOURce<hw>]:BB:C2K:BSTation<st>:CGRoup<di0>:COFFset<ch>:TPC:READ
 <Read>

The command sets the read out mode for the bit pattern of the power control bits.

The bit pattern is defined with the commands `:BB:C2K:BST<n>:CGRoup<n>:COFFset<n>:TPC . . .`

Power control is available for sub channel types F-DCCH and F-FCH. F-DCCH is only generated for radio configurations 3, 4 and 5.

For the traffic channels, this value is specific for the selected radio configuration.

Parameters:

<Read> CONTInuous | S0A | S1A | S01A | S10A

CONTInuous

The bit pattern is used cyclically.

S0A

The bit pattern is used once, then the power control bit sequence continues with 0 bits.

S1A

The bit pattern is used once, then the power control bit sequence continues with 1 bit.

S01A

The bit pattern is used once and then the power control bit sequence is continued with 0 bits and 1 bit alternately.

S10A

The bit pattern is used once and then the power control bit sequence is continued with 1 bit and 0 bits alternately.

*RST: CONTInuous

Example: `BB:C2K:BST2:CGR1:RCON 4`
 Selects radio configuration RC4 for the first traffic channel of base station 2. This setting is valid for all sub channels of the traffic channel. With RC4, the traffic channel includes an F-DCCH.

`BB:C2K:BST2:CGR1:COFF4:TPC:READ S0A`
 'the bit pattern is used once, after which a 0 sequence is generated (applies to F-DCCH of the first traffic channel of base station 2).

Manual operation: See ["Read Out Mode \(Power Control\) - BS"](#) on page 64

[:SOURCE<hw>]:BB:C2K:BSTation<st>:CGRoup<di0>:COFFset<ch>:TYPE?

Queries the channel type.

The channel type is firmly fixed for channel numbers 0-1 to 0-14 (CGR0:COFF1 to CGR0:COFF14), i.e. for the special channels (control and packet channels). The remaining channel numbers are assigned to the individual code channels of the eight possible traffic channels. In this case, the first traffic channel occupies the range 1-1 to 1-8 (CGR1:COFF1 to CGR1:COFF8), the second occupies the range 2-1 to 2-8 (CGR2:COFF1 to CGR2:COFF8), etc. Since the type and number of code channels depends on the radio configuration of the channel, the channels x-2 to x-8 are variously occupied. X-1 is always the fundamental channel (F-FCH) of the traffic channel.

Return values:

<Type> F-PICH | F-SYNC | F-PCH | F-TDPICH | F-APICH |
F-ATDPICH | F-BCH | F-QPCH | F-CPCCH | F-CACH |
F-CCCH | F-DCCH | F-FCH | F-SCH | F-PDCCH | F-PDCH

Example:

BB:C2K:BST2:CGR0:COFF12:TYPE?

Queries type of channel 0 to 12 of base station 2.

Response: F-PDCCH

Usage:

Query only

Manual operation: See ["Channel Type"](#) on page 56

**[:SOURCE<hw>]:BB:C2K:BSTation<st>:CGRoup<di0>:COFFset<ch>:WCODE
<WCode>**

Assigns the Walsh Code to the channel. The standard assigns a fixed walsh code to some channels (F-PICH, for example, always uses Walsh code 0). Generally, the Walsh code can only be varied within the range specified by the standard.

For the traffic channels, this value is specific for the selected radio configuration.

The value range of the Walsh code depends on the frame length, the channel coding type and the data rate.

If one of these parameters is changed so that the set Walsh code gets invalid, the next permissible value is automatically set.

Parameters:

<WCode> integer
Range: 0 to 255
*RST: 0

Example:

BB:C2K:BST1:CGR3:COFF5:WCOD 23

Assigns Walsh code 23 to sub channel 3 to 5 of base station 1.

Manual operation: See ["Walsh Code"](#) on page 59

[[:SOURce<hw>]:BB:C2K:BSTation<st>:CGRoup<di0>:COFFset<ch>:WLENgth?

Queries the Walsh Code length of the channel. For the traffic channels, this value is specific for the selected radio configuration.

Return values:

<WLength> integer
 Range: 0 to 255
 *RST: 0

Example:

BB:C2K:BST1:CGR3:COFF5:WLEN?
 queries Walsh code length of sub channel 3-5 of base station 1.
 Response: 64
 the Walsh code length is 64.

Usage: Query only

Manual operation: See "[Walsh Length - More Parameters BS](#)" on page 63

**[[:SOURce<hw>]:BB:C2K:BSTation<st>:CGRoup<di0>:RCONfiguration
<RConfiguration>**

Selects the radio configuration for the traffic channel. The settings of the channel table parameters are specific for the selected radio configuration.

Parameters:

<RConfiguration> 1 | 2 | 3 | 4 | 5
 *RST: Traffic channel 1/2: 3; all other traffic channels: 1

Example:

BB:C2K:BST2:CGR1:RCON 4
 selects radio configuration RC4 for the first traffic channel of base station 2. This setting is valid for all sub channels of the traffic channel. With RC4, the traffic channel includes a F-DCCH.

Manual operation: See "[Radio Configuration \(RC\)](#)" on page 58

[[:SOURce<hw>]:BB:C2K:BSTation<st>:DCONflict:MODE <Mode>

The command switches the order of the spreading codes.

Parameters:

<Mode> HAD | BREV

HAD

the code channels are displayed in the order determined by the Hadamard matrix. The codes are numbered as Walsh codes according to the standard.

BREV

the code channels are displayed in the order defined by the Orthogonal Variable Spreading Factor (OVSF) code tree (3GPP code).

*RST: HAD

Example: BB:C2K:BST2:DCON:MODE HAD
selects that the codes are numbered as Walsh codes according to the standard.

Manual operation: See ["Order - Code Domain BS"](#) on page 53

[:SOURCE<hw>]:BB:C2K:BSTation<st>:DCONflict:RESolve

The command resolves existing domain conflicts by modifying the Walsh codes of the affected channels.

Example: BB:C2K:BST2:DCON:STAT?
queries whether a code domain conflict exists for base station 2.
Response: 1
there is a conflict.
BB:C2K:BST2:DCON:RES
resolves the code domain error by modifying the Walsh codes of the affected channels.

Usage: Event

Manual operation: See ["Domain Conflict"](#) on page 61

[:SOURCE<hw>]:BB:C2K:BSTation<st>:DCONflict[:STATe]?

The command queries whether there is (response 1) or is not (response 0) a conflict (overlap) in the hierarchically-structured Walsh codes.

Return values:

<State> 0 | 1 | OFF | ON

Example: BB:C2K:BST2:DCON:STAT?
queries whether a code domain conflict exists for base station 2.
Response: 0
there is no conflict.

Usage: Query only

Manual operation: See ["Domain Conflict"](#) on page 61

[:SOURCE<hw>]:BB:C2K:BSTation<st>:PDCHannel:PINterval <PInterval>

The command sets the interval between two data packets for F-PDCH. The range depends on the ARB settings sequence length (:BB:C2K:SLENgth). The values 80 ms, 40 ms, 20 ms, 10 ms and 5 ms can always be set, and the maximum value is 2000 ms. All intermediate values must satisfy the condition:

Sequence Length * 80ms/2ⁿ, where n is a whole number.

Parameters:

<PInterval> float
 Range: 5 ms to 2000 ms
 Increment: 0.005
 *RST: 20 ms

Example:

BB:C2K:BST2:PDCH:PINT 10 ms
 sets an interval of 10 ms between two data packets.

Manual operation: See "[Packet Interval - More Params F-PDCHs BS](#)" on page 72

[:SOURCE<hw>]:BB:C2K:BSTation<st>:PDCHannel:PSETup <PSetup>

Selects for F-PDCH if all subpackets are generated using the same settings or if the settings of subchannel 1 are valid for all sub channels. However, the value of "Number of Bits per Encoder Packet" is a quality of the complete encoder packet, therefore it is always set for all sub packet channels via the entry for sub channel 1.

Parameters:

<PSetup> 0 | 1 | OFF | ON
ON
 Packet parameters can be changed only for sub packet 1, all sub packets are generated with these settings.
OFF
 Packet parameters can be set individually for each sub packet.
 *RST: 1

Example:

BB:C2K:BST2:PDCH:PSET OFF
 selects that all sub packets can be configured separately.

Manual operation: See "[Same Packet Setup... - More Params F-PDCHs BS](#)" on page 73

[:SOURCE<hw>]:BB:C2K:BSTation<st>:PDCHannel:SUBPacket<di>:ID <Id>

The command selects the sub packet ID for F_PDCH. The sub packet ID determines the sub packet symbol selection and selects one of four available subpackets of the encoder packets. The SPID of sub packet 1 is always 1.

Parameters:

<Id> 0 | 1 | 2 | 3
 Range: 0 to 3
 *RST: 0

Example:

BB:C2K:BST2:PDCH:SUBP3:ID 3
 selects SPID 3 for sub packet 3.

Manual operation: See "[Subpacket ID \(SPID\) - More Params F-PDCHs BS](#)" on page 74

[:SOURce<hw>]:BB:C2K:BSTation<st>:PDCHannel:SUBPacket<di>:PARAmeters
<Parameters>

Selects a fixed combination of parameters "Bits per Encoder Packet", "Number of 32-Chip Walsh Channels", "Subpacket Data Rate", "Number of Slots per Subpackets" and "Modulation Order". These combinations are shown in the following list in the form of a table for all five parameters.

The complete range of 127 possible combinations is only available for subpacket 1. If "Same Packet Setup for all Subpackets" is enabled (SOUR:BB:C2K:BST2:PDCH:PSET ON), this command is only valid for subpacket 1.

Parameter of command SOUR:BB: C2K:BST: PDCH:PAR	Number of Bits per Encoder Packet	Number of 32-Chip Walsh Channels	Subpacket Data Rate (kbps)	Number of Slots per Subpacket	Modulation Order
1	2328	28	1862.4	1	8-PSK
2	3864	27	1545.6	2	QPSK
3	3096	26	2476.8	1	16-QAM
4	3864	26	3091.2	1	16-QAM
5	1560	25	1248.0	1	QPSK
6	2328	25	1862.4	1	8-PSK
7	3096	25	1238.4	2	QPSK
8	3864	25	1545.6	2	8-PSK
9	2328	23	931.2	2	QPSK
10	2328	23	1862.4	1	16-QAM
11	3096	23	2476.8	1	16-QAM
12	3864	23	1545.6	2	8-PSK
13	1560	22	1248.0	1	QPSK
14	3096	22	1238.4	2	QPSK
15	1560	21	1248.0	1	8-PSK
16	3096	21	1238.4	2	8-PSK
17	3096	21	2476.8	1	16-QAM
18	3864	21	1545.6	2	8-PSK
19	1560	20	624.0	2	QPSK
20	2328	20	465.6	4	QPSK
21	2328	20	931.2	2	QPSK
22	2328	20	1862.4	1	16-QAM
23	3096	20	619.2	4	QPSK

Parameter of command SOUR:BB: C2K:BST: PDCH:PAR	Number of Bits per Encoder Packet	Number of 32-Chip Walsh Channels	Subpacket Data Rate (kbps)	Number of Slots per Subpacket	Modulation Order
24	408	19	326.4	1	QPSK
25	792	19	316.8	2	QPSK
26	792	19	633.6	1	QPSK
27	1560	19	1248.0	1	8-PSK
28	3096	19	1238.4	2	8-PSK
29	3864	19	772.8	4	QPSK
30	3864	19	1545.6	2	16-QAM
31	2328	18	1862.4	1	16-QAM
32	1560	17	1248.0	1	8-PSK
33	2328	17	931.2	2	QPSK
34	3096	17	1238.4	2	8-PSK
35	3864	17	1545.6	2	16-QAM
36	2328	16	1862.4	1	16-QAM
37	3096	16	619.2	4	QPSK
38	3864	16	772.8	4	QPSK
39	792	15	633.6	1	QPSK
40	1560	15	624.0	2	QPSK
41	1560	15	1248.0	1	16-QAM
42	2328	15	931.2	2	8-PSK
43	3096	15	1238.4	2	16-QAM
44	3864	15	1545.6	2	16-QAM
45	1560	14	312.0	4	QPSK
46	2328	14	465.6	4	QPSK
47	3864	14	772.8	4	QPSK
48	3864	14	1545.6	2	16-QAM
49	792	13	633.6	1	QPSK
50	1560	13	624.0	2	QPSK
51	1560	13	1248.0	1	16-QAM
52	2328	13	931.2	2	8-PSK
53	3096	13	619.2	4	QPSK
54	3096	13	1238.4	2	16-QAM

Parameter of command SOUR:BB: C2K:BST: PDCH:PAR	Number of Bits per Encoder Packet	Number of 32-Chip Walsh Channels	Subpacket Data Rate (kbps)	Number of Slots per Subpacket	Modulation Order
55	3864	13	1545.6	2	16-QAM
56	1560	12	1248.0	1	16-QAM
57	3096	12	1238.4	2	16-QAM
58	3864	12	772.8	4	8-PSK
59	408	11	326.4	1	QPSK
60	792	11	158.4	4	QPSK
61	792	11	316.8	2	QPSK
62	792	11	633.6	1	QPSK
63	1560	11	624.0	2	QPSK
64	1560	11	1248.0	1	16-QAM
65	2328	11	465.6	4	QPSK
66	2328	11	931.2	2	16-QAM
67	3096	11	619.2	4	QPSK
68	3096	11	1238.4	2	16-QAM
69	3864	11	772.8	4	8-PSK
70	792	10	633.6	1	8-PSK
71	1560	10	624.0	2	8-PSK
72	2328	10	931.2	2	16-QAM
73	3096	10	619.2	4	8-PSK
74	792	9	633.6	1	8-PSK
75	1560	9	312.0	4	QPSK
76	1560	9	624.0	2	8-PSK
77	2328	9	465.6	4	QPSK
78	2328	9	931.2	2	16-QAM
79	3096	9	619.2	4	8-PSK
80	3864	9	772.8	4	16-QAM
81	408	8	163.2	2	QPSK
82	408	8	326.4	1	QPSK
83	792	8	316.8	2	QPSK
84	792	8	633.6	1	16-QAM
85	1560	8	624.0	2	16-QAM

Parameter of command SOUR:BB: C2K:BST: PDCH:PAR	Number of Bits per Encoder Packet	Number of 32-Chip Walsh Channels	Subpacket Data Rate (kbps)	Number of Slots per Subpacket	Modulation Order
86	2328	8	465.6	4	8-PSK
87	2328	8	931.2	2	16-QAM
88	3096	8	619.2	4	16-QAM
89	3864	8	772.8	4	16-QAM
90	408	7	326.4	1	QPSK
91	792	7	316.8	2	QPSK
92	792	7	633.6	1	16-QAM
93	1560	7	312.0	4	QPSK
94	1560	7	624.0	2	16-QAM
95	2328	7	465.6	4	8-PSK
96	3096	7	619.2	4	16-QAM
97	3864	7	772.8	4	16-QAM
98	408	6	326.4	1	QPSK
99	792	6	158.4	4	QPSK
100	792	6	316.8	2	QPSK
101	792	6	633.6	1	16-QAM
102	1560	6	312.0	4	QPSK
103	1560	6	624.0	2	16-QAM
104	2328	6	465.6	4	16-QAM
105	3096	6	619.2	4	16-QAM
106	408	5	163.2	2	QPSK
107	408	5	326.4	1	8-PSK
108	792	5	316.8	2	8-PSK
109	1560	5	312.0	4	8-PSK
110	2328	5	465.6	4	16-QAM
111	408	4	81.6	4	QPSK
112	408	4	163.2	2	QPSK
113	408	4	326.4	1	16-QAM
114	792	4	158.4	4	QPSK
115	792	4	316.8	2	16-QAM
116	1560	4	312.0	4	16-QAM

Parameter of command SOUR:BB: C2K:BST: PDCH:PAR	Number of Bits per Encoder Packet	Number of 32-Chip Walsh Channels	Subpacket Data Rate (kbps)	Number of Slots per Subpacket	Modulation Order
117	2328	4	465.6	4	16-QAM
118	408	3	81.6	4	QPSK
119	408	3	163.2	2	QPSK
120	408	3	326.4	1	16-QAM
121	792	3	158.4	4	QPSK
122	792	3	316.8	2	16-QAM
123	1560	3	312.0	4	16-QAM
124	408	2	81.6	4	QPSK
125	408	2	163.2	2	16-QAM
126	792	2	158.4	4	16-QAM
127	408	1	81.6	4	16-QAM

Parameters:

<Parameters> 1 to 127
*RST: 1

Example:

BB:C2K:BST2:PDCH:SUBP1:PAR 48
selects combination of parameters with index 48 (see following table).

Manual operation:

See "PDCH Subpacket Table Parameters - More Params F-PDCHs BS" on page 74

[:SOURce<hw>]:BB:C2K:BSTation<st>:PDCHannel:SUBPacket<di>:STATe
<State>

This command activates/deactivates the selected sub packet for F_PDCH. Sub packet 1 is always active.

Parameters:

<State> 0 | 1 | OFF | ON
*RST: OFF

Example:

BB:C2K:BST2:PDCH:SUBP3:STAT ON
activates sub packet 3.

Manual operation:

See "Subpacket State - More Params F-PDCHs BS" on page 74

[:SOURCE<hw>]:BB:C2K:BSTation<st>:PDCHannel:SUBPacket<di>:TOFFset <TOffset>

Sets start of the sub packet relative to the start of the packet interval. The offset is entered in slots. Sub packet 1 has offset 0. The value range for the individual subpackets depends on the settings of the other subpackets. The time slot offsets of the other sub packet have to be entered in ascending order. Also, two packets cannot be sent at the same time.

In total the maximum value depends on the selected packet interval and the number of slots per sub packet as follows:

Packet Interval/1.25 ms - Number of Slots per Subpacket.

Parameters:

<TOffset> integer
 Range: 0 to max
 *RST: 0|1|2|3

Example: BB:C2K:BST2:PDCH:SUBP3:TOFF 4
 enters at time slot offset of 4 slots. Sub packet 3 is sent 4 slots after the begin of the packet interval.

Manual operation: See ["Time Slot Offset - More Params F-PDCHs BS"](#) on page 74

[:SOURCE<hw>]:BB:C2K:BSTation<st>:PDCHannel:SUBPacket<di>:WCODes?

The command queries the resulting Walsh codes for the selected sub packet of F-PDCH. Packet channels may be assigned to more than one code channel.

Return values:

<WCodes> string

Example: BB:C2K:BST2:PDCH:SUBP3:RES:WCOD?
 queries the resulting Walsh codes for sub packet 3 of F-PDCH of base station 2.
 Response: "31, 15, 23"
 the resulting walsh codes are 31,15,23.

Usage: Query only

Manual operation: See ["Resulting Walsh Codes for Subpacket - More Params F-PDCHs BS"](#) on page 76

[:SOURCE<hw>]:BB:C2K:BSTation<st>:PDCHannel:WINDex <WIndex>

The command selects a standard Walsh set for F-PDCH. Four different sets are defined in the standard.

Parameters:

<WIndex> 0 | 1 | 2 | 3
 *RST: 0

Example: BB:C2K:BST2:PDCH:WIND 2
selects set 2 for PDCH of base station 2.

Manual operation: See "[Walsh Code Column Index - More Params F-PDCHs BS](#)" on page 73

[:SOURCE<hw>]:BB:C2K:BSTation<st>:PNOffset <PnOffset>

The command sets the PN offset (short code) of the base station. The PN offset permits signals of different base stations to be distinguished.

Parameters:

<PnOffset> integer
Range: 0 to 511
*RST: 0

Example: BB:C2K:BST3:PNOF 123
sets a PN offset of 123 for base station 3.

Manual operation: See "[PN Offset - BS](#)" on page 50

[:SOURCE<hw>]:BB:C2K:BSTation<st>:QWSet <QwSet>

The command selects the quasi orthogonal Walsh code set. The standard defines three different sets.

The quasi-orthogonal Walsh codes are used for a given channel if `[:SOURCE<hw>] : BB:C2K:BSTation<st>:CGRoup<di0>:COFFset<ch>:QWCode:STATE` is ON.

Parameters:

<QwSet> integer
Range: 1 to 3
*RST: 1

Example: BB:C2K:BST2:QWS 2
selects set 2 for base station 2.

Manual operation: See "[Quasi orth Walsh Set - BS](#)" on page 50

[:SOURCE<hw>]:BB:C2K:BSTation<st>:STATE <State>

The command activates and deactivates the specified base station.

Parameters:

<State> 0 | 1 | OFF | ON
*RST: OFF

Example: BB:C2K:BST2:STAT OFF
deactivates base station 2.

Manual operation: See "[Base Station/Mobile Station State](#)" on page 30

[:SOURce<hw>]:BB:C2K:BSTation<st>:TDElay <TDelay>

Sets the time shift of the selected base station compared to base station 1.

Parameters:

<TDelay> integer
 Range: 0 to dynamic
 *RST: 0
 Default unit: chip

Example: BB:C2K:BST2:TDEL 256
 shifts base station 2 by 256 chips compared to base station 1.

Manual operation: See "Time Delay - BS" on page 50

[:SOURce<hw>]:BB:C2K:BSTation<st>:TDIVersity <TDiversity>

The command activates and deactivates signal calculation with transmit diversity (OFF). To activate transmit diversity, the antenna must be specified whose signals are to be simulated (ANT1 or ANT2).

The diversity scheme is selected using command [:SOURce<hw>]:BB:C2K:BSTation<st>:TDIVersity:MODE.

Parameters:

<TDiversity> OFF | ANT1 | ANT2
OFF
 No transmit diversity.
ANT1
 Calculate and apply the output signal for antenna 1.
ANT2
 Calculate and apply the output signal for antenna 2.
 *RST: OFF

Example: BB:C2K:BST2:TDIV ANT2
 Activates transmit diversity, the signal of antenna 2 is simulated.

Manual operation: See "Transmit Diversity - BS" on page 49

[:SOURce<hw>]:BB:C2K:BSTation<st>:TDIVersity:MODE <Mode>

The command selects the diversity scheme.

Command [:SOURce<hw>]:BB:C2K:BSTation<st>:TDIVersity activates transmit diversity and selects the antenna.

Parameters:

<Mode> OTD | STS

OTD

Orthogonal Transmit Diversity Mode.

STS

Space Time Spreading Mode.

*RST: OTD

Example:

BB:C2K:BST2:TDIV:MODE OTD

selects scheme OTD for Transmit Diversity.

BB:C2K:BST2:TDIV ANT2

activates transmit diversity, the signal of antenna 2 is simulated.

Manual operation: See "Diversity Mode - BS" on page 50

5.8 Mobile Station Settings

The `SOURCE:BB:C2K:MSTation` system contains commands for setting mobile stations.

The commands of this system only take effect when the CDMA2000 standard is activated, the UP transmission direction is selected and the particular mobile station is enabled:

- `SOURCE:BB:C2K:STATE ON`
- `SOURCE:BB:C2K:LINK UP`
- `SOURCE:BB:C2K:MSTation2:STATE ON`



For the code channels of a traffic channels, the settings of the channel table parameters are specific for the selected radio configuration. I.e. a complete set of settings exists for each of the four possible radio configurations.

<code>[SOURCE<hw>]:BB:C2K:MSTation:ADDITIONAL:COUNT</code>	145
<code>[SOURCE<hw>]:BB:C2K:MSTation:ADDITIONAL:LCMask:STEP</code>	145
<code>[SOURCE<hw>]:BB:C2K:MSTation:ADDITIONAL:POWER:OFFSet</code>	145
<code>[SOURCE<hw>]:BB:C2K:MSTation:ADDITIONAL:STATE</code>	146
<code>[SOURCE<hw>]:BB:C2K:MSTation:ADDITIONAL:TDElay:STEP</code>	146
<code>[SOURCE<hw>]:BB:C2K:MSTation:PRESet</code>	146
<code>[SOURCE<hw>]:BB:C2K:MSTation<st>:CCODing:MODE</code>	147
<code>[SOURCE<hw>]:BB:C2K:MSTation<st>:CHANnel<ch>:DATA</code>	147
<code>[SOURCE<hw>]:BB:C2K:MSTation<st>:CHANnel<ch>:DATA:DSElect</code>	148
<code>[SOURCE<hw>]:BB:C2K:MSTation<st>:CHANnel<ch>:DATA:PATtern</code>	149
<code>[SOURCE<hw>]:BB:C2K:MSTation<st>:CHANnel<ch>:DATA:RATE</code>	149
<code>[SOURCE<hw>]:BB:C2K:MSTation<st>:CHANnel<ch>:FLENgth</code>	150
<code>[SOURCE<hw>]:BB:C2K:MSTation<st>:CHANnel<ch>:POWER</code>	150
<code>[SOURCE<hw>]:BB:C2K:MSTation<st>:CHANnel<ch>:SPReading?</code>	150
<code>[SOURCE<hw>]:BB:C2K:MSTation<st>:CHANnel<ch>:STATE</code>	151
<code>[SOURCE<hw>]:BB:C2K:MSTation<st>:CHANnel<ch>:TYPE?</code>	151

[SOURce<hw>]:BB:C2K:MSTation<st>:CHANnel<ch>:WCODe?.....	152
[SOURce<hw>]:BB:C2K:MSTation<st>:LCMask.....	152
[SOURce<hw>]:BB:C2K:MSTation<st>:MODE.....	152
[SOURce<hw>]:BB:C2K:MSTation<st>:RCONfiguration.....	153
[SOURce<hw>]:BB:C2K:MSTation<st>:STATe.....	154
[SOURce<hw>]:BB:C2K:MSTation<st>:TPC:DATA.....	154
[SOURce<hw>]:BB:C2K:MSTation<st>:TPC:DATA:DSELEct.....	154
[SOURce<hw>]:BB:C2K:MSTation<st>:TPC:DATA:PATTern.....	155
[SOURce<hw>]:BB:C2K:MSTation<st>:TPC:MISuse.....	155
[SOURce<hw>]:BB:C2K:MSTation<st>:TPC:PSTep.....	156
[SOURce<hw>]:BB:C2K:MSTation<st>:TPC:READ.....	156

[SOURce<hw>]:BB:C2K:MSTation:ADDITIONAL:COUNT <Count>

Sets the number of additional mobile stations.

Parameters:

<Count> integer
 Range: 1 to 64
 *RST: 4

Example:

```
BB:C2K:MST:ADD:COUN 20
sets 20 additional mobile stations.
BB:C2K:MST:ADD:POW:OFFS -3.0
sets the power offset to -3 dB.
BB:C2K:MST:ADD:LCM:STEP #H1
sets the step width for increasing the LC mask to 1.
BB:C2K:MST:ADD:STAT ON
connects the 20 mobile stations to the CDMA signal.
```

Manual operation: See ["Number of Additional MS"](#) on page 47

[SOURce<hw>]:BB:C2K:MSTation:ADDITIONAL:LCMask:STEP <Step>

Sets the step width for increasing the LC mask of the additional mobile stations. The start value is the LC mask of MS4.

Parameters:

<Step> 24 bits
 *RST: #H1

Example:

```
BB:C2K:MST:ADD:LCM:STEP #H55
sets the step width for increasing the long code mask to #H55.
```

Manual operation: See ["LC Mask Step"](#) on page 47

[SOURce<hw>]:BB:C2K:MSTation:ADDITIONAL:POWER:OFFSet <Offset>

The command sets the power offset of the active channels of the additional mobile stations relative to the power of the active channels of the reference station MS4.

The offset applies to all the additional mobile stations. The resultant overall power must fall within the range 0 ... - 80 dB. If the value is above or below this range, it is limited automatically.

Parameters:

<Offset> float
 Range: -80 dB to 0 dB
 Increment: 0.01 dB
 *RST: 0 dB

Example: BB:C2K:MST:ADD:POW:OFFS -3.0
 sets the offset to -3 dB.

Manual operation: See ["Power Offset"](#) on page 47

[:SOURCE<hw>]:BB:C2K:MSTation:ADDITIONAL:STATE <State>

The command activates additional mobile stations.

Parameters:

<State> 0 | 1 | OFF | ON
 *RST: OFF

Example: BB:C2K:MST:ADD:STAT ON
 connects the additional mobile stations to the CDMA2000 signal.

Manual operation: See ["State"](#) on page 47

[:SOURCE<hw>]:BB:C2K:MSTation:ADDITIONAL:TDELAY:STEP <Step>

Sets the step width for the time delay of the additional mobile stations to one another. The start value returns the time delay of MS4.

Parameters:

<Step> integer
 Range: 0 to 1535 (1 frame)
 Increment: 1
 *RST: 0
 Default unit: chip

Example: BB:C2K:MST:ADD:TDEL:STEP 256
 shifts each of the mobile stations 256 chips apart, starting from the time delay of MS4.

Manual operation: See ["Time Delay Step"](#) on page 48

[:SOURCE<hw>]:BB:C2K:MSTation:PRESet

A standardized default for all the mobile stations (*RST values specified for the commands).

See ["Reset All Mobile Stations"](#) on page 28 for an overview.

Example: SOURCE1:BB:C2K:MSTation:PRESet
Usage: Event
Manual operation: See "[Reset All Mobile Stations](#)" on page 28

[:SOURCE<hw>]:BB:C2K:MSTation<st>:CCODing:MODE <Mode>

The command selects the channel coding mode.

Parameters:

<Mode> OFF | COMPLETE | NOINterleaving | OINterleaving

OFF

Channel coding is deactivated.

COMPLETE

The complete channel coding is performed. The channel coding procedure can slightly vary depending on channel type, frame length and data rate.

OINterleaving

Except for the block interleaver, the whole channel coding procedure is carried out.

NOINterleaving

In this mode, only block interleaver is used for coding.

*RST: COMPLETE

Example: BB:C2K:MST:CCOD:MODE OFF
 Deactivates channel coding for mobile station 1.

Manual operation: See "[Channel Coding - MS](#)" on page 78

[:SOURCE<hw>]:BB:C2K:MSTation<st>:CHANnel<ch>:DATA <Data>

The command sets the data source for the specified channel.

The data source for the power control bits is selected with the command [:SOURCE<hw>]:BB:C2K:MSTation<st>:TPC:DATA. For the traffic channels, this value is specific for the selected radio configuration.

Parameters:

<Data> ZERO | ONE | PATtern | PN9 | PN11 | PN15 | PN16 | PN20 | PN21 | PN23 | DLISt

PNxx

The pseudo-random sequence generator is used as the data source. Different random sequence lengths can be selected.

DLISt

A data list is used. The data list is selected with the command `[:SOURce<hw>] :BB:C2K:MSTation<st>:CHANnel<ch>:DATA:DSElect`.

ZERO | ONE

Internal 0 and 1 data is used.

PATtern

Internal data is used. The bit pattern for the data is defined by the command `[:SOURce<hw>] :BB:C2K:MSTation<st>:CHANnel<ch>:DATA:PATtern`.

*RST: PN9

Example:

BB:C2K:MST1:CHAN2:DATA PN16

Selects as the data source for channel 2 of mobile station 1, internal PRBS data with a sequence length of $2^{16}-1$.

Manual operation: See "Data List Management " on page 24

[:SOURce<hw>] :BB:C2K:MSTation<st>:CHANnel<ch>:DATA:DSElect <DSelect>

The command selects the data list for the DLISt data source selection.

The lists are stored as files with the fixed file extensions `*.dm_iqd` in a directory of the user's choice. The directory applicable to the following commands is defined with the command `MMEMoRY:CDIR`. To access the files in this directory, you only have to give the file name, without the path and the file extension.

For the traffic channels, this value is specific for the selected radio configuration.

Parameters:

<DSelect> string

Example:

BB:C2K:MST1:CHAN1:DATA DLIS

selects the Data Lists data source.

MMEM:CDIR "<root>Lists"

selects the directory for the data lists.

BB:C2K:MST1:CHAN1:DATA:DSEL "dpcch_13"

selects file 'cdma_13' as the data source. This file must be in specified directory and it must have the file extension

`*.dm_iqd`.

Manual operation: See "Data List Management " on page 24

[:SOURce<hw>]:BB:C2K:MSTation<st>:CHANnel<ch>:DATA:PATtern <Pattern>

Sets the bit pattern for the data component when the PATtern data source is selected. The first parameter determines the bit pattern (choice of hexadecimal, octal or binary notation), the second specifies the number of bits to use. The maximum length is 64 bits.

For the traffic channels, this value is specific for the selected radio configuration.

Parameters:

<Pattern> 64 bits

Example:

BB:C2K:MST1:CHAN1:DATA PATT

selects Pattern data source.

BB:C2K:MST1:CHAN1:DATA:PATT #H800FFFF80003FFE,
60

defines the bit pattern.

Manual operation: See "[Data - MS](#)" on page 83

[:SOURce<hw>]:BB:C2K:MSTation<st>:CHANnel<ch>:DATA:RATE <Rate>

The command sets the data rate for the specified channel. The value range depends on the channel type, the selected radio configuration and the frame length.

For the traffic channels, this value is specific for the selected radio configuration.

The value range of the data rate depends on the channel type and the frame length. If the frame length is changed so that the set data rate becomes invalid, the next permissible value is automatically set.

Parameters:

<Rate> DR1K2 | DR1K3 | DR1K5 | DR1K8 | DR2K4 | DR2K7 | DR3K6 |
DR4K8 | DR7K2 | DR9K6 | DR14K4 | DR19K2 | DR28K8 |
DR38K4 | DR57K6 | DR76K8 | DR115K2 | DR153K6 |
DR230K4 | DR259K2 | DR307K2 | DR460K8 | DR518K4 |
DR614K4 | DR1036K8 | NUSed

*RST: R-DCCH: DR9K6; R-FCH: DR1K5; R-SCH: DR1K5;
R-ACC: DR4K8

Example:

BB:C2K:MST2:MODE TRAF

selects operating mode traffic.

BB:C2K:MST2:RCON 3

selects radio configuration 3 for the traffic channel.

BB:C2K:MST2:CHAN3:DATA:RATE DR4K8

sets a data rate of 4.8 kbps for channel 3 f mobile station 2 (R-FCH in this configuration).

Manual operation: See "[Data Rate - MS](#)" on page 82

[:SOURce<hw>]:BB:C2K:MSTation<st>:CHANnel<ch>:FLENgth <FLength>

The command sets the frame length of the selected channel. The value range depends on the channel type and the selected radio configuration

For the traffic channels, this value is specific for the selected radio configuration.

The frame length affects the data rates that are possible within a channel. Changing the frame length may lead to a change of data rate.

Parameters:

<FLength> 5 | 10 | 20 | 26.6 | 40 | 80
 *RST: 20 ms

Example:

BB:C2K:MST:CHAN3:FLEN 5 ms
 sets the frame length of sub channel 3 to 5 ms.

Manual operation: See "[Frame Length - MS](#)" on page 82

[:SOURce<hw>]:BB:C2K:MSTation<st>:CHANnel<ch>:POWER <Power>

Sets the channel power relative to the powers of the other channels. This setting also determines the starting power of the channel for Misuse Output Power Control.

With the command [:SOURce<hw>] :BB:C2K:POWer:ADJust, the power of all the activated channels is adapted so that the total power corresponds to 0 dB. This does not change the power ratio among the individual channels.

For the traffic channels, this value is specific for the selected radio configuration.

Parameters:

<Power> float
 Range: -80 to 0
 Increment: 0.01
 *RST: 0

Example:

BB:C2K:MST2:CHAN3:POW -10dB
 Sets the channel power of sub channel 3 of mobile station 2 dB to -10 dB relative to the power of the other channels.

Manual operation: See "[Power - MS](#)" on page 83

[:SOURce<hw>]:BB:C2K:MSTation<st>:CHANnel<ch>:SPReading?

Queries the spreading factor of the channel. The spreading factor corresponds to the length of the employed Walsh code. The Walsh codes to be used are specified by the standard and cannot be chosen.

For the traffic channels, this value is specific for the selected radio configuration.

Return values:

<Spreading> integer
 Range: 0 to 255
 *RST: 0

- Example:** BB:C2K:MST2:CHAN1:SPR?
Queries the spreading factor of channel 1 of mobile station 2.
Response: 32
- Usage:** Query only
- Manual operation:** See "Spread- MS" on page 83

[:SOURCE<hw>]:BB:C2K:MSTation<st>:CHANNEL<ch>:STATE <State>

This command activates/deactivates the selected channel.

For the traffic channels, this value is specific for the selected radio configuration.

Parameters:

<State> 0 | 1 | OFF | ON
*RST: OFF

- Example:** BB:C2K:MST2:CHAN2:STAT OFF
deactivates sub channel 2 of mobile station 2.

- Manual operation:** See "Channel State - MS" on page 84

[:SOURCE<hw>]:BB:C2K:MSTation<st>:CHANNEL<ch>:TYPE?

The command queries the channel type. The channel type depends on the selected operating mode and, for the sub channels of the traffic channel, from the selected radio configuration.

Return values:

<Type> R-PICH | R-ACH | R-EACH | R-CCCH | R-DCCH | R-FCH |
R-SCCH | R-SCH2 | R-SCH1

R-ACH
Access Channel.

R-EACH
Enhanced Access Channel

R-CCCH
Common Control Channel

R-PICH
Pilot Channel.

R-DCCH
Dedicated Control Channel

R-FCH
Fundamental Channel

R-SCHx
Supplemental Channel 1 | 2

R-SCCH
Supplemental Control Channel

Example: BB:C2K:MST2:CHAN2:TYPE?
queries type of channel 2.
Response: R-SCCH
channel 2 is a Supplemental Control Channel.

Usage: Query only

Manual operation: See "Channel Type - MS" on page 81

[:SOURCE<hw>]:BB:C2K:MSTation<st>:CHANnel<ch>:WCODe?

Queries the Walsh code. The standard assigns a fixed walsh code to some channels. For the traffic channels, this value is specific for the selected radio configuration.

Return values:

<WCode> integer
Range: 0 to 255
*RST: 0

Example: BB:C2K:MST1:CHAN3:WCOD?
Queries the Walsh code of channel 3 of mobile station 1.
Response: 3
The Walsh code is 3.

Usage: Query only

Manual operation: See "Walsh - MS" on page 82

[:SOURCE<hw>]:BB:C2K:MSTation<st>:LCMask <LcMask>

Sets the mask of the Long Code Generator of the mobile station.

Parameters:

<LcMask> 42 bits
*RST: #H0

Example: BB:C2K:MST1:LCM #H55
sets the Long Codes to #H55.

Manual operation: See "LC Mask (hex) - MS" on page 78

[:SOURCE<hw>]:BB:C2K:MSTation<st>:MODE <Mode>

The command selects operating mode for the mobile station. The channel-specific parameters are set with commands SOUR:BB:C2K:MST<n>:CHANnel<n>: . . . n.

Parameters:

<Mode> TRAFFic | ACCess | EACCess | CCONtrol

TRAFFic

The mobile station generates a single traffic channel. A traffic channel consists of up to eight sub channels depending on the selected radio configuration (R-FCH, R-SCCH, R-SCH, R-DCCH). This mode corresponds to the standard mode of a mobile station during voice and data transmission.

ACCess

The mobile station generates an access channel (R-ACH). This channel is needed to set up the connection between the mobile station and the base station.

EACCess

The mobile station generates an enhanced access channel (R-ACH) and a pilot channel (R-PICH).

CCONtrol

The mobile station generates a common control channel (R-ACH) and a pilot channel (R-PICH).

*RST: TRAFFic

Example:

BB:C2K:MST1:MODE TRAF

Switches the mobile station into standard mode - voice and data transmission.

Manual operation: See "[Operation Mode - MS](#)" on page 77

[:SOURCE<hw>]:BB:C2K:MSTation<st>:RCONfiguration <RConfiguration>

The command selects the radio configuration for the traffic channel.

The settings of the channel table parameters are specific for the selected radio configuration.

A separate set of settings of all channel table parameters for each radio configuration is provided. If the radio configuration is changed, the set of channel table values belonging to this RC is automatically activated.

Parameters:

<RConfiguration> 1 | 2 | 3 | 4

*RST: 3

Example:

BB:C2K:MST2:MODE TRAF

switches mobile station 2 into standard mode - voice and data transmission.

BB:C2K:MST2:RCON 3

selects radio configuration 3. With RC3, the traffic channel includes five sub channels.

Manual operation: See "[Radio Configuration - MS](#)" on page 77

[:SOURce<hw>]:BB:C2K:MSTation<st>:STATe <State>

The command activates and deactivates the specified mobile station.

Parameters:

<State> 0 | 1 | OFF | ON
 *RST: OFF

Example: BB:C2K:MST2:STAT OFF
 deactivates mobile station 2.

Manual operation: See "[Base Station/Mobile Station State](#)" on page 30

[:SOURce<hw>]:BB:C2K:MSTation<st>:TPC:DATA <Data>

Sets the data source for the power control bits of the traffic channels.

Parameters:

<Data> ZERO | ONE | PATTErn | DLISt

DLISt

A data list is used. The data list is selected with the command
[\[:SOURce<hw>\]:BB:C2K:MSTation<st>:TPC:DATA:DSElect](#).

ZERO | ONE

Internal 0 and 1 data is used.

PATTErn

Internal data is used. The bit pattern for the data is defined by
 the command [\[:SOURce<hw>\]:BB:C2K:MSTation<st>:TPC:DATA:PATTErn](#). The maximum length is 64 bits.

*RST: ZERO

Example: BB:C2K:MST2:TPC:DATA PATT
 Selects Pattern data source for the power control bits. The bit
 pattern is defined with the following command.
 BB:C2K:MST2:TPC:DATA: PATT #H3F, 8
 Defines the bit pattern.

Manual operation: See "[Data List Management](#) " on page 24

[:SOURce<hw>]:BB:C2K:MSTation<st>:TPC:DATA:DSElect <DSelect>

The command selects the data list for the DLISt data source selection.

The lists are stored as files with the fixed file extensions *.dm_iqd in a directory of the user's choice. The directory applicable to the following commands is defined with the command `MMEMoRY:CDIR`. To access the files in this directory, you only have to give the file name, without the path and the file extension.

Parameters:

<DSelect> <data list name>

Example: BB:C2K:MST2:TPC:DATA DLIS
selects the DLIS data source.
M MEM:CDIR "<root>Lists"
selects the directory for the data lists.
BB:C2K:MST2:TPC:DATA:DSEL 'cdma_ch4'
'selects the file "cdma_ch4" as the data source. This file must be in specified directory and it must have the file extension *.dm_iqd.

Manual operation: See ["Data List Management"](#) on page 24

[:SOURce<hw>]:BB:C2K:MSTation<st>:TPC:DATA:PATTern <Pattern>

Sets the bit pattern for the PATTern selection. The maximum bit pattern length is 64 bits.

Parameters:

<Pattern> 64 bits

Example: BB:C2K:MST2:TPC:DATA:PATT #H3F, 8
defines the bit pattern for the power control-bits.

Manual operation: See ["Data Source \(Power Control\) - MS"](#) on page 79

[:SOURce<hw>]:BB:C2K:MSTation<st>:TPC:MISuse <MisUse>

The command activates/deactivates the use of the power control data for controlling the mobile station output power. On the uplink, the power control bits are used exclusively for controlling the mobile station output power. Power control puncturing is not defined for controlling the base station power.

The bit pattern (see commands :BB:C2K:MSTation<n>:TPC...) of the power control bits w is used to control the channel power. A "1" leads to an increase of channel powers, a "0" to a reduction of channel powers. Channel power is limited to the range 0 dB to -80 dB. The step width of the change is defined with the command [:SOURce<hw>]:BB:C2K:MSTation<st>:TPC:PSTep.

Parameters:

<MisUse> 0 | 1 | OFF | ON
*RST: OFF

Example: BB:C2K:MST2:TPC:MIS ON
activates regulation of channel power for mobile station 2 via the power control bit pattern.
BB:C2K:MST2:TPC:PST 1 dB
sets the step width for the change of channel powers to 1 dB.

Manual operation: See ["Misuse for Output Power Control - MS"](#) on page 79

[[:SOURce<hw>]:BB:C2K:MSTation<st>:TPC:PSTep <PStep>

The command defines the step width for the change of channel powers in the case of "mis-" use of the power control bits.

Parameters:

<PStep> float
 Range: -10 to 10 dB
 Increment: 0.01 dB
 *RST: 0 dB

Example: BB:C2K:MST2:TPC:PST 0.1 dB
 sets the step width for the change of channel powers to 1 dB.

Manual operation: See ["Power Step - MS"](#) on page 80

[[:SOURce<hw>]:BB:C2K:MSTation<st>:TPC:READ <Read>

The command sets the read out mode for the bit pattern of the power control bits.

The bit pattern is defined with the commands :BB:C2K:MST<n>:TPC....

Parameters:

<Read> CONTInuous | S0A | S1A | S01A | S10A

CONTInuous

The bit pattern is used cyclically.

S0A

The bit pattern is used once, then the power control bit sequence continues with 0 bits.

S1A

The bit pattern is used once, then the power control bit sequence continues with 1 bit.

S01A

The bit pattern is used once and then the power control bit sequence is continued with 0 bits and 1 bit alternately.

S10A

The bit pattern is used once and then the power control bit sequence is continued with 1 bit and 0 bits alternately.

*RST: CONTInuous

Example: BB:C2K:MST2:TPC:READ S0A
 The bit pattern is used once, after which a 0 sequence is generated (applies to R-DCCH of mobile station 2).

Manual operation: See ["Read Out Mode \(Power Control\) - MS"](#) on page 79

List of Commands

[SOURce]:BB:C2K:VERSion?	93
[SOURce<hw>]:BB:C2K:BSTation:PRESet	114
[SOURce<hw>]:BB:C2K:BSTation:SYNC:CNUMber	115
[SOURce<hw>]:BB:C2K:BSTation:SYNC:LCState	115
[SOURce<hw>]:BB:C2K:BSTation:SYNC:MPRev	115
[SOURce<hw>]:BB:C2K:BSTation:SYNC:NID	116
[SOURce<hw>]:BB:C2K:BSTation:SYNC:PREV	116
[SOURce<hw>]:BB:C2K:BSTation:SYNC:SID	116
[SOURce<hw>]:BB:C2K:BSTation:SYNC:STime	117
[SOURce<hw>]:BB:C2K:BSTation<st>:CGRoup<di0>:COFFset<ch>:CCODing:BINterleaver?	117
[SOURce<hw>]:BB:C2K:BSTation<st>:CGRoup<di0>:COFFset<ch>:CCODing:BITFrame?	118
[SOURce<hw>]:BB:C2K:BSTation<st>:CGRoup<di0>:COFFset<ch>:CCODing:CRC?	118
[SOURce<hw>]:BB:C2K:BSTation<st>:CGRoup<di0>:COFFset<ch>:CCODing:DATA:RATE?	119
[SOURce<hw>]:BB:C2K:BSTation<st>:CGRoup<di0>:COFFset<ch>:CCODing:MODE	119
[SOURce<hw>]:BB:C2K:BSTation<st>:CGRoup<di0>:COFFset<ch>:CCODing:SPUNcture?	120
[SOURce<hw>]:BB:C2K:BSTation<st>:CGRoup<di0>:COFFset<ch>:CCODing:SREPetition?	120
[SOURce<hw>]:BB:C2K:BSTation<st>:CGRoup<di0>:COFFset<ch>:CCODing:TYPE	121
[SOURce<hw>]:BB:C2K:BSTation<st>:CGRoup<di0>:COFFset<ch>:DATA	121
[SOURce<hw>]:BB:C2K:BSTation<st>:CGRoup<di0>:COFFset<ch>:DATA:DSElect	122
[SOURce<hw>]:BB:C2K:BSTation<st>:CGRoup<di0>:COFFset<ch>:DATA:PATtern	123
[SOURce<hw>]:BB:C2K:BSTation<st>:CGRoup<di0>:COFFset<ch>:DATA:RATE	123
[SOURce<hw>]:BB:C2K:BSTation<st>:CGRoup<di0>:COFFset<ch>:DERRor:BIT:RATE	124
[SOURce<hw>]:BB:C2K:BSTation<st>:CGRoup<di0>:COFFset<ch>:DERRor:BIT:STATE	124
[SOURce<hw>]:BB:C2K:BSTation<st>:CGRoup<di0>:COFFset<ch>:DERRor:BLOCK:RATE	124
[SOURce<hw>]:BB:C2K:BSTation<st>:CGRoup<di0>:COFFset<ch>:DERRor:BLOCK:STATE	125
[SOURce<hw>]:BB:C2K:BSTation<st>:CGRoup<di0>:COFFset<ch>:FLENgth	125
[SOURce<hw>]:BB:C2K:BSTation<st>:CGRoup<di0>:COFFset<ch>:LCMask	126
[SOURce<hw>]:BB:C2K:BSTation<st>:CGRoup<di0>:COFFset<ch>:POWer	126
[SOURce<hw>]:BB:C2K:BSTation<st>:CGRoup<di0>:COFFset<ch>:QWCode:STATE	127
[SOURce<hw>]:BB:C2K:BSTation<st>:CGRoup<di0>:COFFset<ch>:REALtime:STATE	127
[SOURce<hw>]:BB:C2K:BSTation<st>:CGRoup<di0>:COFFset<ch>:STATE	127
[SOURce<hw>]:BB:C2K:BSTation<st>:CGRoup<di0>:COFFset<ch>:TPC:DATA	128
[SOURce<hw>]:BB:C2K:BSTation<st>:CGRoup<di0>:COFFset<ch>:TPC:DATA:DSElect	128
[SOURce<hw>]:BB:C2K:BSTation<st>:CGRoup<di0>:COFFset<ch>:TPC:DATA:PATtern	129
[SOURce<hw>]:BB:C2K:BSTation<st>:CGRoup<di0>:COFFset<ch>:TPC:MISuse	130
[SOURce<hw>]:BB:C2K:BSTation<st>:CGRoup<di0>:COFFset<ch>:TPC:PSTep	130
[SOURce<hw>]:BB:C2K:BSTation<st>:CGRoup<di0>:COFFset<ch>:TPC:READ	131
[SOURce<hw>]:BB:C2K:BSTation<st>:CGRoup<di0>:COFFset<ch>:TYPE?	132
[SOURce<hw>]:BB:C2K:BSTation<st>:CGRoup<di0>:COFFset<ch>:WCODE	132
[SOURce<hw>]:BB:C2K:BSTation<st>:CGRoup<di0>:COFFset<ch>:WLENgth?	133
[SOURce<hw>]:BB:C2K:BSTation<st>:CGRoup<di0>:RCONfiguration	133
[SOURce<hw>]:BB:C2K:BSTation<st>:DCONflict:MODE	133
[SOURce<hw>]:BB:C2K:BSTation<st>:DCONflict:RESolve	134
[SOURce<hw>]:BB:C2K:BSTation<st>:DCONflict[STATE]?	134
[SOURce<hw>]:BB:C2K:BSTation<st>:PDCHannel:PINterval	134
[SOURce<hw>]:BB:C2K:BSTation<st>:PDCHannel:PSETup	135
[SOURce<hw>]:BB:C2K:BSTation<st>:PDCHannel:SUBPacket<di>:ID	135

[SOURce<hw>]:BB:C2K:BSTation<st>:PDCHannel:SUBPacket<di>:PARAMeters.....	136
[SOURce<hw>]:BB:C2K:BSTation<st>:PDCHannel:SUBPacket<di>:STATE.....	140
[SOURce<hw>]:BB:C2K:BSTation<st>:PDCHannel:SUBPacket<di>:TOFFset.....	141
[SOURce<hw>]:BB:C2K:BSTation<st>:PDCHannel:SUBPacket<di>:WCODes?.....	141
[SOURce<hw>]:BB:C2K:BSTation<st>:PDCHannel:WINDex.....	141
[SOURce<hw>]:BB:C2K:BSTation<st>:PNOFFset.....	142
[SOURce<hw>]:BB:C2K:BSTation<st>:QWSet.....	142
[SOURce<hw>]:BB:C2K:BSTation<st>:STATE.....	142
[SOURce<hw>]:BB:C2K:BSTation<st>:TDELay.....	143
[SOURce<hw>]:BB:C2K:BSTation<st>:TDIVersity.....	143
[SOURce<hw>]:BB:C2K:BSTation<st>:TDIVersity:MODE.....	143
[SOURce<hw>]:BB:C2K:CLIPping:LEVel.....	96
[SOURce<hw>]:BB:C2K:CLIPping:MODE.....	97
[SOURce<hw>]:BB:C2K:CLIPping:STATE.....	97
[SOURce<hw>]:BB:C2K:CLOCK:MODE.....	105
[SOURce<hw>]:BB:C2K:CLOCK:MULTIplier.....	105
[SOURce<hw>]:BB:C2K:CLOCK:SOURce.....	106
[SOURce<hw>]:BB:C2K:CLOCK:SYNChronization:EXECute.....	106
[SOURce<hw>]:BB:C2K:CLOCK:SYNChronization:MODE.....	107
[SOURce<hw>]:BB:C2K:COPIY:COFFset.....	87
[SOURce<hw>]:BB:C2K:COPIY:DESTination.....	87
[SOURce<hw>]:BB:C2K:COPIY:EXECute.....	87
[SOURce<hw>]:BB:C2K:COPIY:SOURce.....	88
[SOURce<hw>]:BB:C2K:CRATe:VARiation.....	89
[SOURce<hw>]:BB:C2K:CRATe?.....	88
[SOURce<hw>]:BB:C2K:FILTer:PARAmeter:APCO25.....	94
[SOURce<hw>]:BB:C2K:FILTer:PARAmeter:COsine.....	94
[SOURce<hw>]:BB:C2K:FILTer:PARAmeter:GAUSSs.....	94
[SOURce<hw>]:BB:C2K:FILTer:PARAmeter:LPASSs.....	95
[SOURce<hw>]:BB:C2K:FILTer:PARAmeter:LPASSEVM.....	95
[SOURce<hw>]:BB:C2K:FILTer:PARAmeter:PGAuss.....	95
[SOURce<hw>]:BB:C2K:FILTer:PARAmeter:RCOSine.....	96
[SOURce<hw>]:BB:C2K:FILTer:PARAmeter:SPHase.....	96
[SOURce<hw>]:BB:C2K:FILTer:TYPe.....	94
[SOURce<hw>]:BB:C2K:IQSWap[STATE].....	89
[SOURce<hw>]:BB:C2K:LINK.....	89
[SOURce<hw>]:BB:C2K:MSTation:ADDITIONal:COUNT.....	145
[SOURce<hw>]:BB:C2K:MSTation:ADDITIONal:LCMask:STEP.....	145
[SOURce<hw>]:BB:C2K:MSTation:ADDITIONal:POWER:OFFSet.....	145
[SOURce<hw>]:BB:C2K:MSTation:ADDITIONal:STATE.....	146
[SOURce<hw>]:BB:C2K:MSTation:ADDITIONal:TDELay:STEP.....	146
[SOURce<hw>]:BB:C2K:MSTation:PRESet.....	146
[SOURce<hw>]:BB:C2K:MSTation<st>:CCODing:MODE.....	147
[SOURce<hw>]:BB:C2K:MSTation<st>:CHANnel<ch>:DATA.....	147
[SOURce<hw>]:BB:C2K:MSTation<st>:CHANnel<ch>:DATA:DSElect.....	148
[SOURce<hw>]:BB:C2K:MSTation<st>:CHANnel<ch>:DATA:PATTern.....	149
[SOURce<hw>]:BB:C2K:MSTation<st>:CHANnel<ch>:DATA:RATE.....	149
[SOURce<hw>]:BB:C2K:MSTation<st>:CHANnel<ch>:FLEngth.....	150
[SOURce<hw>]:BB:C2K:MSTation<st>:CHANnel<ch>:POWER.....	150
[SOURce<hw>]:BB:C2K:MSTation<st>:CHANnel<ch>:SPReading?.....	150

[SOURce<hw>]:BB:C2K:MSTation<st>:CHANnel<ch>:STATe.....	151
[SOURce<hw>]:BB:C2K:MSTation<st>:CHANnel<ch>:TYPE?.....	151
[SOURce<hw>]:BB:C2K:MSTation<st>:CHANnel<ch>:WCODe?.....	152
[SOURce<hw>]:BB:C2K:MSTation<st>:LCMask.....	152
[SOURce<hw>]:BB:C2K:MSTation<st>:MODE.....	152
[SOURce<hw>]:BB:C2K:MSTation<st>:RCONfiguration.....	153
[SOURce<hw>]:BB:C2K:MSTation<st>:STATe.....	154
[SOURce<hw>]:BB:C2K:MSTation<st>:TPC:DATA.....	154
[SOURce<hw>]:BB:C2K:MSTation<st>:TPC:DATA:DSElect.....	154
[SOURce<hw>]:BB:C2K:MSTation<st>:TPC:DATA:PATTern.....	155
[SOURce<hw>]:BB:C2K:MSTation<st>:TPC:MISuse.....	155
[SOURce<hw>]:BB:C2K:MSTation<st>:TPC:PSTep.....	156
[SOURce<hw>]:BB:C2K:MSTation<st>:TPC:READ.....	156
[SOURce<hw>]:BB:C2K:POWer:ADJust.....	90
[SOURce<hw>]:BB:C2K:POWer[:TOTal]?.....	90
[SOURce<hw>]:BB:C2K:PPARameter:CRESt.....	108
[SOURce<hw>]:BB:C2K:PPARameter:EXECute.....	108
[SOURce<hw>]:BB:C2K:PPARameter:PCHannel[:STATe].....	108
[SOURce<hw>]:BB:C2K:PPARameter:PIChannel[:STATe].....	109
[SOURce<hw>]:BB:C2K:PPARameter:RCONfiguration.....	109
[SOURce<hw>]:BB:C2K:PPARameter:SCHannel[:STATe].....	109
[SOURce<hw>]:BB:C2K:PPARameter:TCHannel:COUNT.....	110
[SOURce<hw>]:BB:C2K:PPARameter:TCHannel:DATA:RATE.....	110
[SOURce<hw>]:BB:C2K:PPARameter:TCHannel:DCCHannel[:STATe].....	111
[SOURce<hw>]:BB:C2K:PPARameter:TCHannel:FCHannel[:STATe].....	111
[SOURce<hw>]:BB:C2K:PPARameter:TCHannel:FLENgth.....	111
[SOURce<hw>]:BB:C2K:PPARameter:TCHannel:SCHannel:COUNT.....	112
[SOURce<hw>]:BB:C2K:PRESet.....	90
[SOURce<hw>]:BB:C2K:SETTing:CATalog?.....	90
[SOURce<hw>]:BB:C2K:SETTing:DELeTe.....	91
[SOURce<hw>]:BB:C2K:SETTing:LOAD.....	91
[SOURce<hw>]:BB:C2K:SETTing:STORe.....	91
[SOURce<hw>]:BB:C2K:SETTing:STORe:FAST.....	92
[SOURce<hw>]:BB:C2K:SLENgth.....	92
[SOURce<hw>]:BB:C2K:STATe.....	92
[SOURce<hw>]:BB:C2K:TRIGger:ARM:EXECute.....	99
[SOURce<hw>]:BB:C2K:TRIGger:EXECute.....	99
[SOURce<hw>]:BB:C2K:TRIGger:EXTernal:SYNChronize:OUTPut.....	99
[SOURce<hw>]:BB:C2K:TRIGger:OBASeband:DELAy.....	100
[SOURce<hw>]:BB:C2K:TRIGger:OBASeband:INHibit.....	100
[SOURce<hw>]:BB:C2K:TRIGger:OUTPut:DELAy:FIXed.....	102
[SOURce<hw>]:BB:C2K:TRIGger:OUTPut<ch>:DELAy.....	103
[SOURce<hw>]:BB:C2K:TRIGger:OUTPut<ch>:DELAy:MAXimum?.....	103
[SOURce<hw>]:BB:C2K:TRIGger:OUTPut<ch>:DELAy:MINimum?.....	103
[SOURce<hw>]:BB:C2K:TRIGger:OUTPut<ch>:MODE.....	103
[SOURce<hw>]:BB:C2K:TRIGger:OUTPut<ch>:OFFTime.....	104
[SOURce<hw>]:BB:C2K:TRIGger:OUTPut<ch>:ONTTime.....	104
[SOURce<hw>]:BB:C2K:TRIGger:OUTPut<ch>:PERiod.....	104
[SOURce<hw>]:BB:C2K:TRIGger:RMODE?.....	101
[SOURce<hw>]:BB:C2K:TRIGger:SLENgth.....	101

[:SOURCE<hw>]:BB:C2K:TRIGGER:SLUNIT.....	102
[:SOURCE<hw>]:BB:C2K:TRIGGER:SOURCE.....	99
[:SOURCE<hw>]:BB:C2K:TRIGGER[:EXTERNAL<ch>]:DELAY.....	100
[:SOURCE<hw>]:BB:C2K:TRIGGER[:EXTERNAL<ch>]:INHIBIT.....	101
[:SOURCE<hw>]:BB:C2K:WAVEFORM:CREATE.....	93
[:SOURCE<hw>]:BB:C2K[:TRIGGER]:SEQUENCE.....	98

Index

Symbols

(Mis-) use for output power control - BS 65, 130
 (Mis-) use for output power control - MS 79, 155

A

Accept - Copy 87
 Accept - predefined settings 46
 Accept - Predefined Settings 108
 Access 77
 Additional MS 47, 146
 Adjust total Power to 0 dB 29
 Application cards 8
 Application notes 8
 Arm 37

B

B x T 31, 94
 Base station default values 27
 Baseband Clipping 32
 Baseband filter 31, 94
 Bit Error insertion - BS1 71
 Bit Error Rate - BS1 71
 Bit reversed 53, 133
 Block Error insertion - BS1 71
 Block Error Rate - BS1 71
 Block interleaver - BS 68
 Block Interleaver - BS 117
 Brochure 8

C

CDMA channel number 69
 CDMA Channel Number - BS 115
 CDMA Version 93
 Channel coding 10
 Channel Coding Mode - BS 66
 Channel Coding Mode - MS 78
 Channel graph - BS 54
 Channel number 56
 Channel Number- MS 81
 Channel Power 60
 Channel Power - MS 83
 Channel state 61
 Channel state - MS 84
 Channel State - MS 151
 Channel Type 56
 Channel Type - MS 81, 151
 Channel types 10
 Chip rate variation 32
 Clipping Level 34, 96
 Clipping Mode 34, 97
 Clipping State 32
 Clock Mode 43
 Clock Multiplier 43
 Clock Source 42
 Code domain 51
 Code domain conflict 61
 Code domain conflict - BS 51
 Code Domain Conflict - BS 134
 Code domain graph - BS 51
 Coder Type 67

Coder Type - BS 121
 Common control 77
 Conventions
 SCPI commands 85
 Convolution coder 67
 Convolution Coder - BS 121
 Copy Base Station 29, 87
 Copy from Source 29, 88
 Copy Mobile Station 29, 87
 CRC Length - BS 67
 Crest factor 32
 Crest factor - Clipping 96
 Crest Factor, desired range 46
 Current range without recalculation 41
 Cutoff Frequency factor 32

D

Data pattern 60
 MS 83
 Data Rate 59
 Data Rate - BS 123
 Data Rate - MS 82, 149
 Data Rate - predefined settings 46
 Data Rate - Predefined Settings 110
 Data sheet 8
 Data source
 BS 60
 MS 83
 Power control 79
 Power Control 64
 Default settings 23, 27
 Default values MS 28
 Delay - Trigger 100
 Diversity Mode- BS 50, 143
 Do Conf - BS 134
 Documentation overview 7
 Downlink 26

E

Effective Data Rate - BS 67, 119
 Enhanced access 77
 Error Protection 67
 Error Protection - BS 121
 External Trigger Delay 100
 External Trigger Inhibit 101

F

Filter parameter 31
 Filter Parameter 94
 Filter Type 31, 94
 Filtering, Clipping, ARB Settings 26, 31
 Fix marker delay to current range 41
 Frame Length 59
 Frame Length - MS 82, 150
 Frame Length - predefined settings 46

G

Generate Waveform File - CDMA2000 25
 Global Trigger/Clock Settings 43

H

Hadamard 53, 133

II/Q swap 35
I/Q-Swap 89
IdPDbGuiCdma2kMpPdchTab 73
Invert Q for correct Baseband Output 35
Invert Q for Correct Baseband Output 89**L**LC Mask 63, 78
LC Mask Step - additional MS 47
LC state (hex) - BS 69
Link direction 26
Link Direction 89
Long code mask 10**M**Marker mode 40
Marker period 40
Marker x Delay 41
Measured external clock 43
Minimum protocol revision level 70
Mobile station default values 28
Modulation 74
Modulation data
 BS 60
More parameters
 BS channel table 61
More Params F-PDCH 71**N**Network identification 70
Number of 32-Chip Walsh Channels - BS 74
Number of additional MS 47
Number of bits per Encoder Packet 74
Number of Slots per subpacket 74
Number of Supplemental Channels - Predef 45
Number of Traffic Channels - Predef 45, 110
Nyquist filter 31, 94**O**ON/OFF ratio 40
Online help 7
Online manual 7
Open source acknowledgment 8
Operating manual 7
Operation mode 77
Order code domain - BS 53
Order Code Domain - BS 133
OSA 8**P**Packet interval - BS 72
Packet Interval - BS 134
Packet Setup - BS 73
PN offset 10
PN Offset - BS 50, 142
Power Offset - additional MS 47
Power Offset - Additional MS 145Power step - BS 66
Power Step - BS 130
Power step - MS 80
Power Step - MS 156
Power/dB 60
Power/dB - MS 83
Protocol revision level 69
Protocol Revision Level - BS 116**Q**Quasi Orthogonal Walsh Set 10
Quasi Orthogonal Walsh Set - BS 50, 142
Quasi-orthogonal Walsh code 60
Quick start guide 7**R**Radio configuration 44
Radio Configuration 58
Radio Configuration - MS 77, 153
Read out mode 64
Read out mode - MS 79
Release notes 8
Reset all Base Stations 27
Reset all Mobile Stations 28
Resulting Walsh code for subpacket - BS 76
Resulting Walsh Code for Subpacket - BS 141
Roll Off 31, 94
Running 37**S**Safety instructions 8
Same Packet Setup - BS 73
Save CDMA settings 24
Save-Recall 24
Select Base Station 30
Select Mobile Station 30
Sequence Length (ARB) 34
Service manual 7
Set to default 23
Signal duration 37
Signal duration unit 37
Source bits / Frame - BS 67
Spread - MS 83
Spreading code number 59
Spreading rate 10
Spreading Rate 26, 88
Standard settings 23
State
 Clipping 97
State - BS 142
State - MS 77, 154
Stopped 37
Subpacket # 73
Subpacket Data Rate - BS 74
Subpacket ID - BS 74, 135
Subpacket state - BS 74
Subpacket State - BS 140
Symbol puncture - BS 68
Symbol Puncture - BS 120
Symbol repetition - BS 68
Sync. Output to External Trigger 38
Synchronization mode 42
System identification 70
System Identification - BS 116

System Time - BS 69

T

Time Delay - BS 50
 Time delay step - additional MS 48
 Time Slot Offset - BS 74
 To destination 29
 To Destination 87
 Total Power 30, 90
 Traffic 77
 Transmission direction 26, 89
 Transmit Diversity - BS 49
 Transmit Diversity Mode - BS 50, 143
 Trigger - Marker 26
 Trigger Delay 39
 Trigger Delay External 100
 Trigger inhibit 40
 Trigger Inhibit External 101
 Trigger Mode 36
 Armed 36
 Auto 36
 Retrigger 36
 Single 36
 Trigger Source 38
 Turbo coder 67
 Turbo Coder - BS 121

U

Uplink 26
 Use Dedicated Control (F-DCCH) - Predef 45
 Use Fundamental (F-FCH) - Predef 45
 Use paging channel (F-PCH) - Predef 45
 Use Paging Channel (F-PCH) - Predef 108
 Use pilot (F-PICH) - Predef 45
 Use Pilot (F-Pich) - Predef 109
 Use Sync (F-Sync) - Predef 45
 User Marker / AUX I/O Settings 43
 User period 40

V

Version 25, 93

W

Walsh - MS 82
 Walsh code 59
 Walsh code column index - BS 73
 Walsh Code Column Index - BS 141
 Walsh code Offset 29
 Walsh Code Offset 87
 Walsh Length - BS 63
 White papers 8